

GX-255~800 Series

CNC Rotary Table

- GX-255H GX-255HL
- GX-320H
- GX-400H
- GX-500H
- GX-630H
- GX-800H

Operation Manual

detron machine co., LTD.

<http://www.detron.com.tw> e-mail: sales@detron.com.tw

export.sales@detron.com.tw

No. 47-5, Zuncian Road, Shengang District 42952, Taichung City, Taiwan

TEL:886-4-2561-6000 FAX:886-4-2562-7872

Table of Contents



1	Introduction.....	1-1
2	Specifications.....	2-1
2.1	GX-255/320/400 Specifications.....	2-1
2.2	GX-500/630/800 Specifications.....	2-2
3	Dimensional Drawing.....	3-1
3.1	GX-255H/HL Dimensional Drawing.....	3-1
3.2	GX-320/400H Dimensional Drawing.....	3-2
3.3	GX-500H Dimensional Drawing.....	3-3
3.4	GX-630/800H Dimensional Drawing.....	3-4
4	Pneumatic/Hydraulic Circuit Diagram.....	4-1
5	Mechanism of Main Parts.....	5-1
5.1	GX-255/320/400 Mechanism of Main Parts.....	5-1
5.2	GX-500/630/800 Mechanism of Main Parts.....	5-2
6	Commissioning Procedure.....	6-1
7	PLC Flow Chart of Control System.....	7-1
8	Zero Return Adjustment and Grid Shift Amount Setting.....	8-1
8.1	Zero Return Adjustment.....	8-1

8.2	Zero Return Grid Shift Amount Setting.....	8-2
9	Backlash Adjustment.....	9-1
9.1	Worm Wheel and Worm Shaft Backlash Inspection.....	9-1
9.2	Worm Wheel and Worm Shaft Backlash Adjustment.....	9-2
9.3	Transmission Gear Backlash Adjustment.....	9-4
10	Clamp/Unclamp Device.....	10-1
11	Lubrication Replacement.....	11-1
12	Troubleshooting.....	12-1
13	Parts List.....	13-1

detron	1 Introduction
Title	1 Introduction

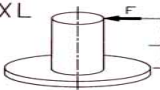

Welcome to detron, thank you for purchasing our CNC Rotary Table. This manual provides important information and detailed instruction for operating and maintaining the machine. We suggest that you peruse the manual thoroughly before operating to ensure optimal conditions of the machine and to effectively prolong its service life.

Keep this manual for convenient consultation.

de tron		2 Specifications				
Title		2.1 GX-255/320/400 Specifications				
No.	Item	Unit	GX-255H/HL	GX-320H	GX-400H	
1	Worktable diameter	mm	Ø255	Ø320	Ø400	
2	Center bore diameter	mm	Ø50H7	Ø70H7	Ø110H7	
3	Through- hole diameter	mm	Ø50	Ø70	Ø110	
4	Height of center	Vertical	mm	190	210	255
5	Height of table	Horizontal	mm	210	235	255
		Vertical (※Remark 1)	mm	340	380	460
6	Width of T-slot	mm	12H7	14H7	14H7	
7	Width of guide block	mm	18	18	18	
8	Drive pressure / method	MPa	5(Hyd.)			
9	Clamping torque	N · m	700	1180	2500	
10	Servo motor type (※Remark 2)	FANUC		α8i	α12i	α12i
		MITSUBISHI		HF154T	HF204S	HF204S
		SIEMENS		1FK7063	1FK7083	1FK7083
		HEIDENHAIN		QSY116E	QSY155B	QSY155B
		YASKAWA		SGMGV13A	SGMGV30A	SGMGV30A
11	Transmission ratio		1/120	1/120	1/144	
12	Max. table speed	min ⁻¹	22.2	22.2	11.1	
13	Allowable loading inertia	Kg · m ²	2.07	4.57	10.2	
14	Resolution	deg.	0.001	0.001	0.001	
15	Indexing accuracy	sec	15	15	15	
16	Repeatability	sec	6	6	6	
17	Net weight (servo motor excluded)	Kg	133	187	292	
18	Allowable loading capacity	Vertical	Kg	100	150	200
		Horizontal	Kg	250	350	500
		Tailstock applied	Kg	250	350	500
19	Allowable load (when table clamped)		N	16000	20000	30000
			N · m	1120	1800	4000
			N · m	700	1180	2500
20	Allowable wheel torque		N · m	550	780	1700

※Remark 1 : Vertical table height excluding eye bolt.

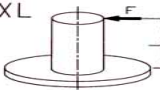
※Remark 2 : Other motor brands available, but the motor cover may be varied as the brand differs.

de tron		2 Specifications				
Title		2.1 GX-500/630/800 Specifications				
No.	Item	Unit	GX-500H	GX-630H	GX-800H	
1	Worktable diameter	mm	Ø500	Ø630	Ø800	
2	Center bore diameter	mm	Ø180H7	Ø270H7	Ø285H7	
3	Through- hole diameter	mm	Ø140	Ø220	Ø240	
4	Height of center	Vertical	mm	310	400	480
5	Height of table	Horizontal	mm	280	325	365
		Vertical (※Remark 1)	mm	560	725	880
6	Width of T-slot	mm	18H7	18H7	22H7	
7	Width of guide block	mm	18	18	18	
8	Drive pressure / method	MPa	5(Hyd.)		3.5(Hyd.)	
9	Clamping torque	N · m	3200	4500	5200	
10	Servo motor type (※Remark 2)	FANUC		α12i	α22i	α22i
		mitsubishi		HF204S	HF354S	HF354S
		SIEMENS		1FK7083	1FK7101	1FK7101
		HEIDENHAIN		QSY155B	QSY190C	QSY190C
		YASKAWA		SGMGV30A	SGMGV30A	SGMGV30A
11	Transmission ratio		1/180	1/180	1/180	
12	Max. table speed	min ⁻¹	11.1	11.1	11.1	
13	Allowable loading inertia	Kg · m ²	19.1	40.5	122.4	
14	Resolution	deg.	0.001	0.001	0.001	
15	Indexing accuracy	sec	15	15	15	
16	Repeatability	sec	6	6	6	
17	Net weight (servo motor excluded)	Kg	395	720	1236	
18	Allowable loading capacity	Vertical	Kg	250	450	800
		Horizontal	Kg	600	800	1500
		Tailstock applied	Kg	600	800	1500
19	Allowable load (when table clamped)		N	40000	49000	50000
			N · m	5000	8500	10000
			N · m	3200	4500	5200
20	Allowable wheel torque		N · m	2500	4300	5000

※Remark 1 : Vertical table height excluding eye bolt.

※Remark 2 : Other motor brands available, but the motor cover may be varied as the brand differs.

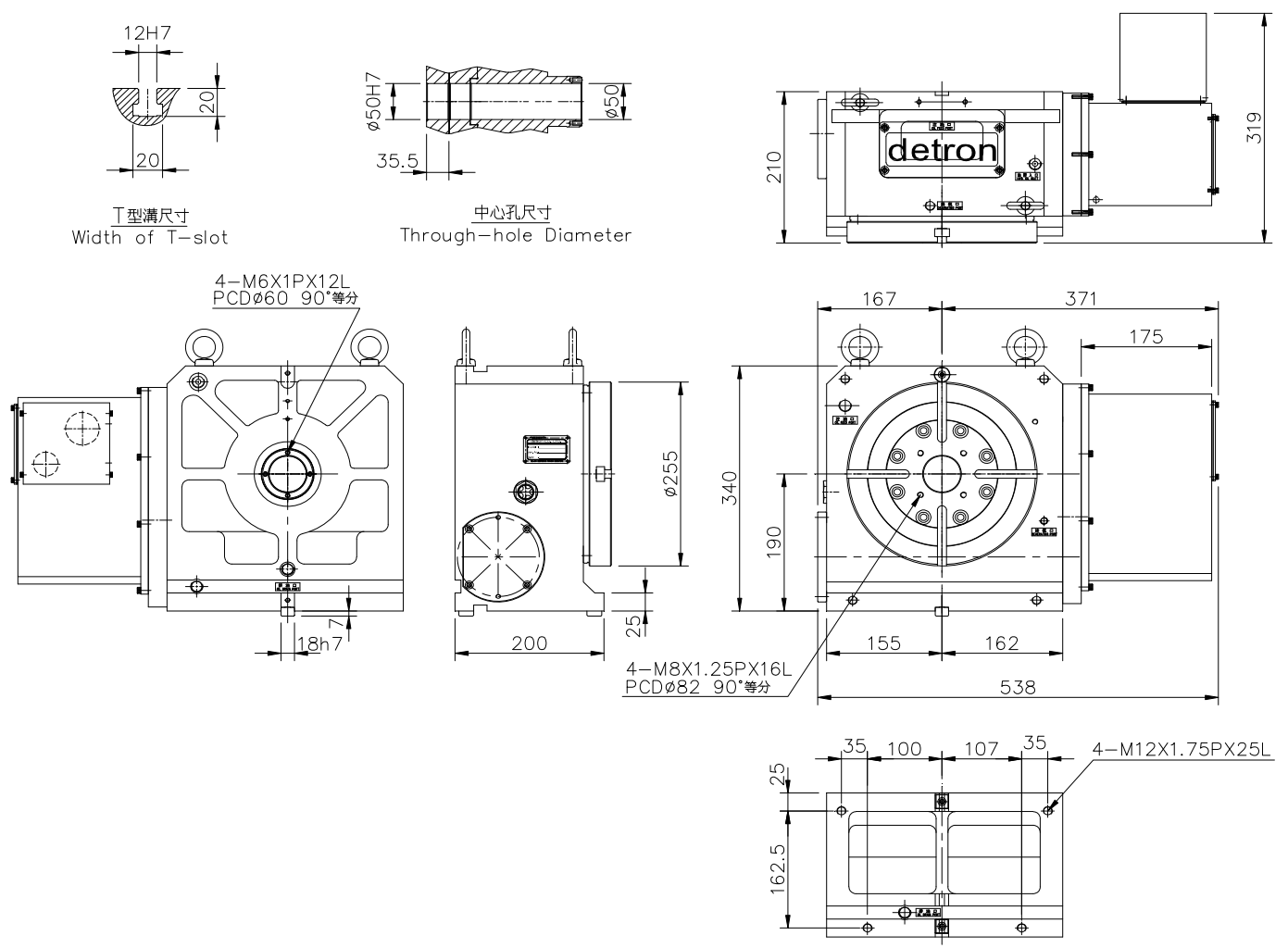

* Dimension Unit: mm

* For GX-255HL, the motor cover is at the left of the worktable.

Fig 3-1

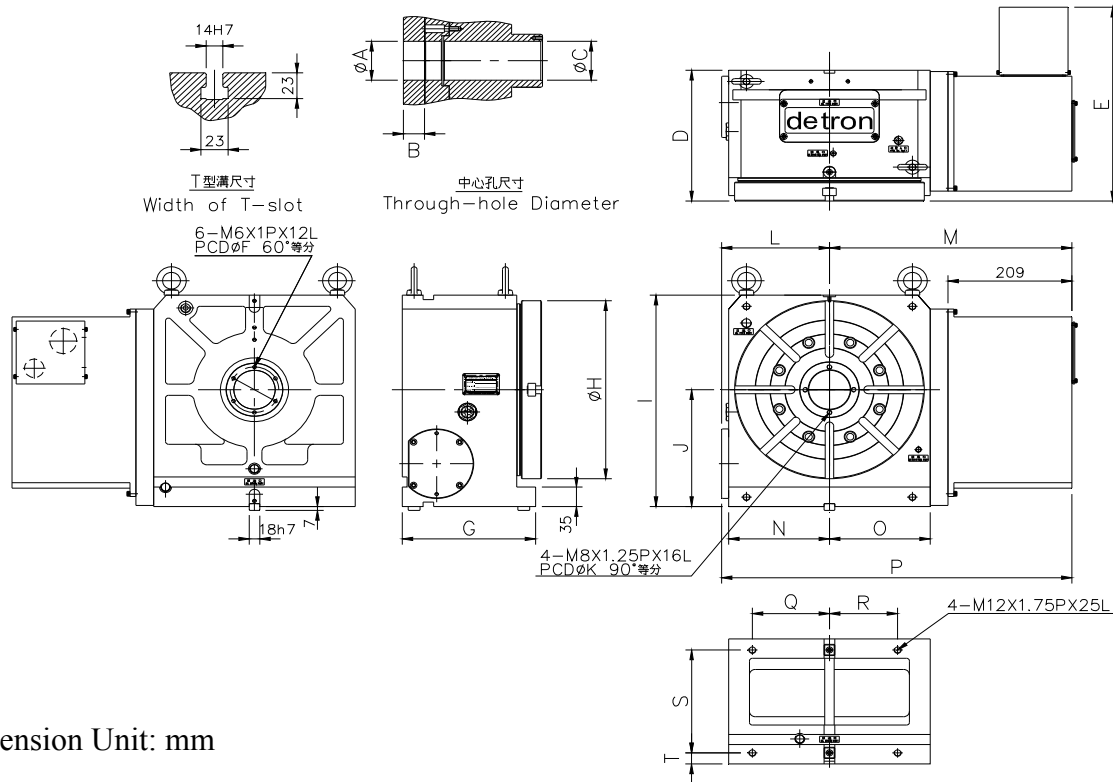

* Dimension Unit: mm

Dimensions and Model

Dimensions Code No.	Model	
	GX-320H	GX-400H
A	70H7	110H7
B	39.5	49.5
C	70	110
D	235	255
E	358	364
F	82	122
G	225	245
H	320	400
I	380	460
J	210	255
K	82	-
L	182	214
M	409	464
N	170	210
O	170	225
P	591	678
Q	130	170
R	115	185
S	20	50
T	185	175

Fig 3-2

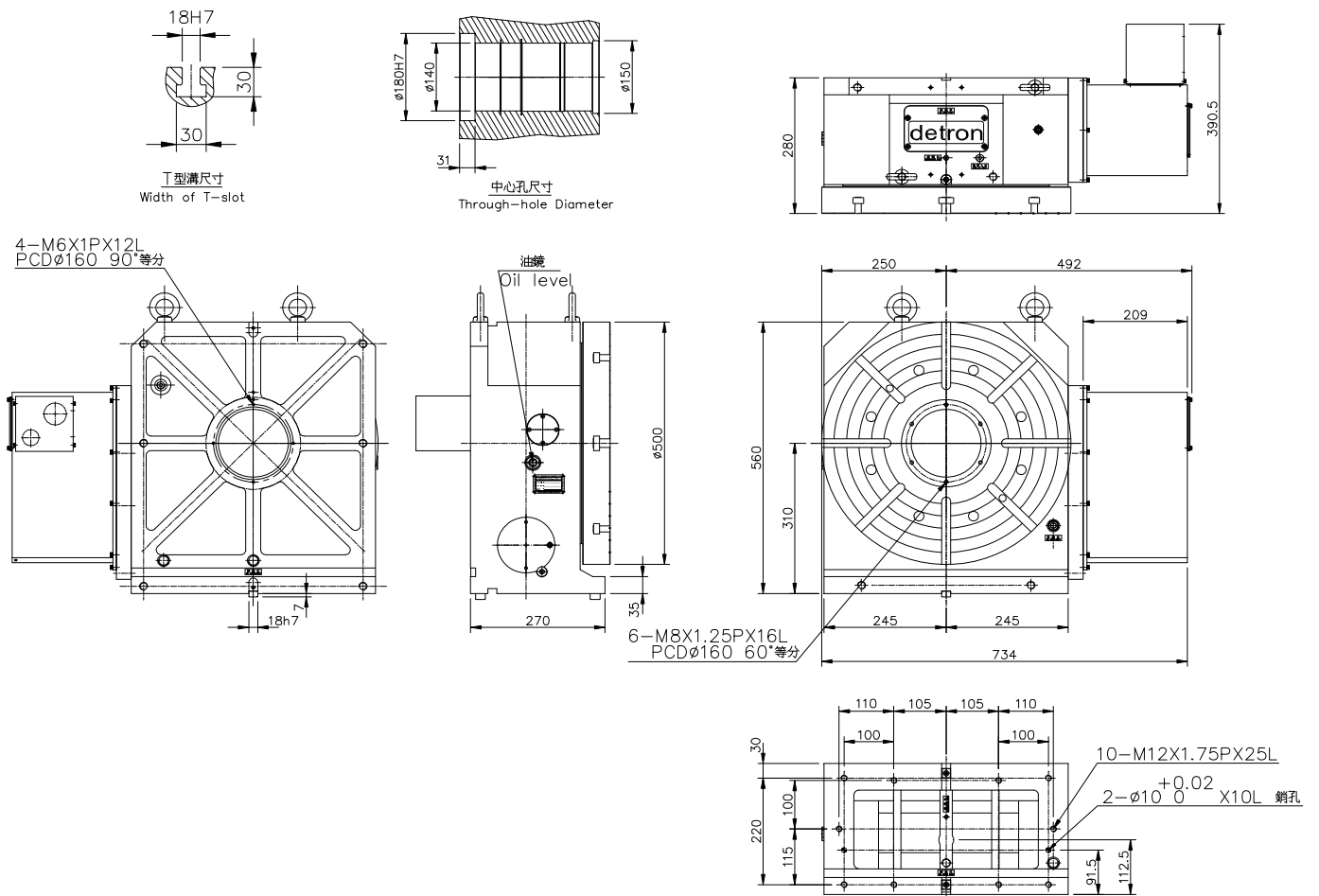

* Dimension Unit: mm

Fig 3-3

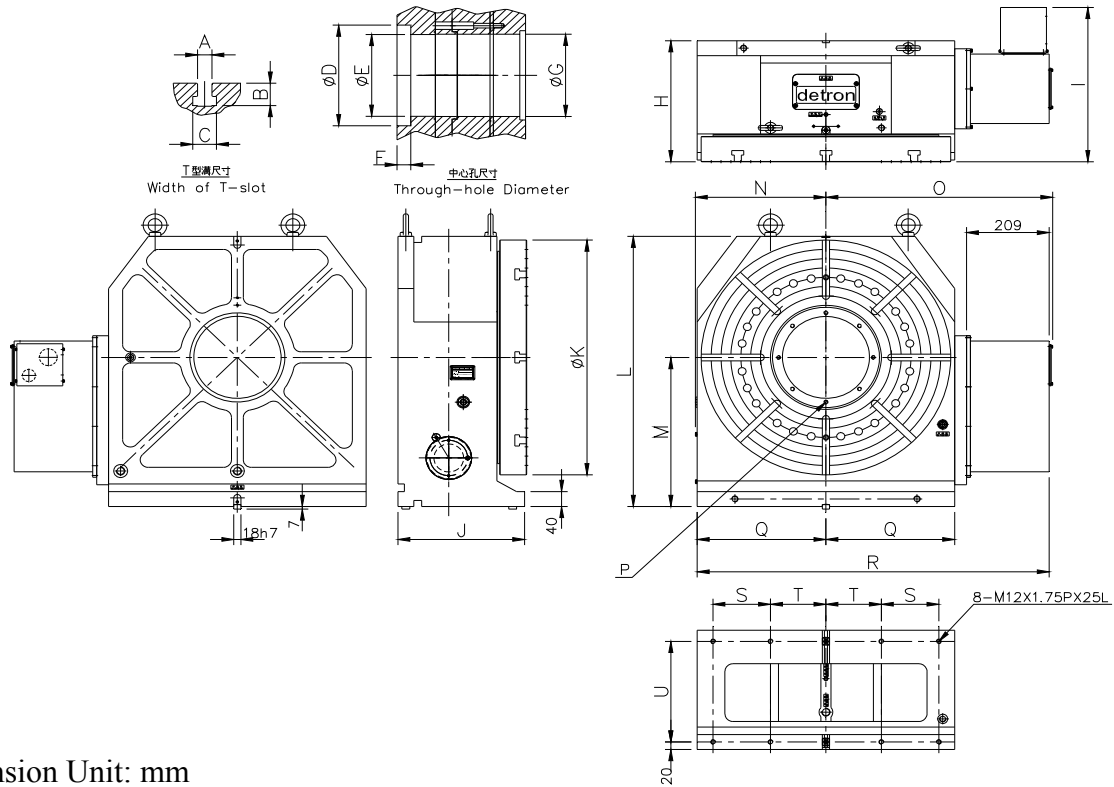

* Dimension Unit: mm

Dimensions and Model		
Dimensions Code No.	Model	
	GX-630H	GX-800H
A	18H7	22H7
B	30	40
C	30	37
D	270H7	285H7
E	220	240
F	35	39
G	220.5	240.5
H	325	365
I	414.5	459.5
J	320	335
K	630	800
L	725	880
M	400	480
N	330	405
O	572	647
P	8-M10X1.5PX20L(PCD Ø240, 8x45°)	4-M10X1.5PX15L(PCD Ø310, 4x90°)
Q	325	400
R	893	1039
S	145	175
T	140	170
U	270	285

Fig 3-4

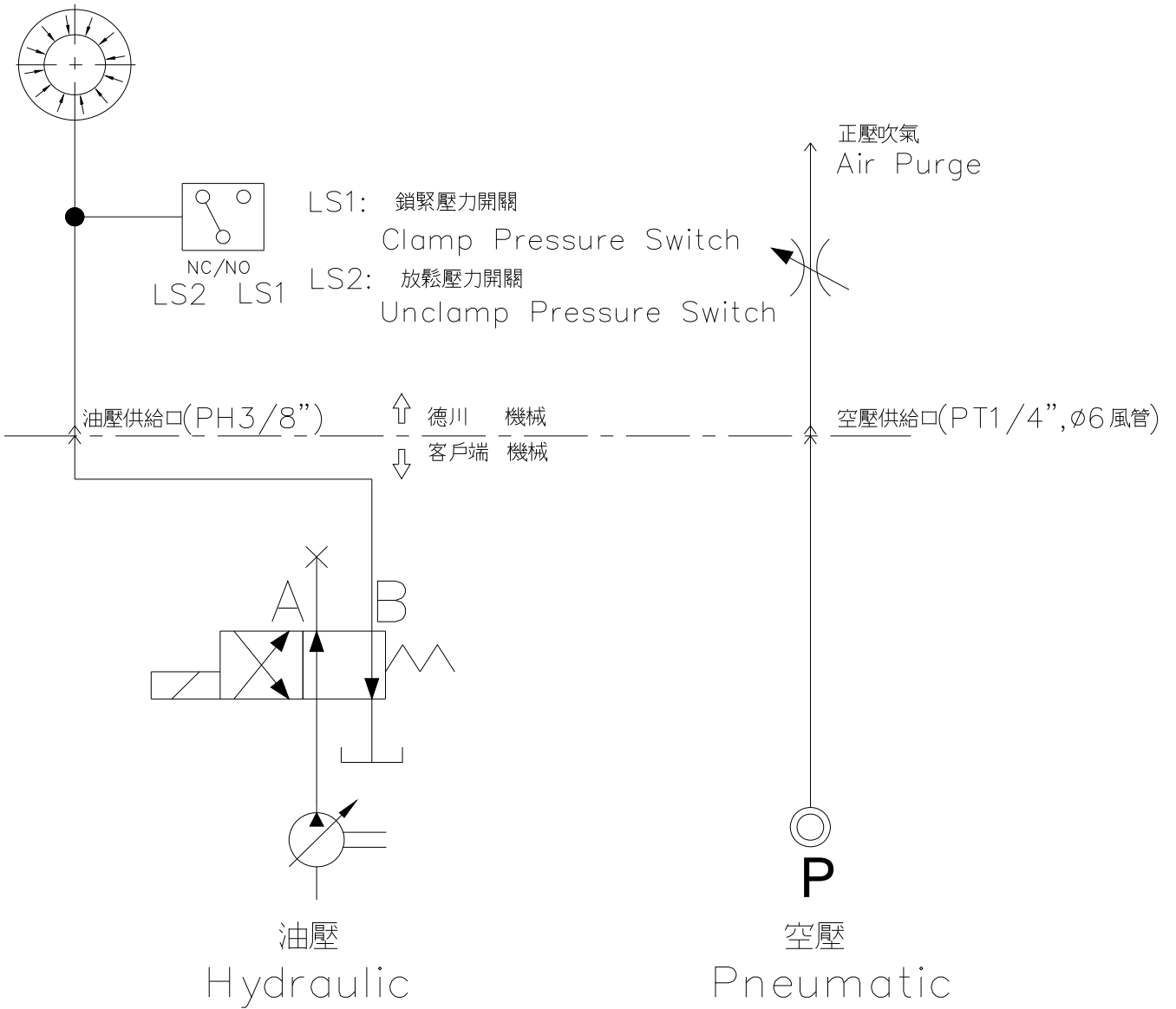
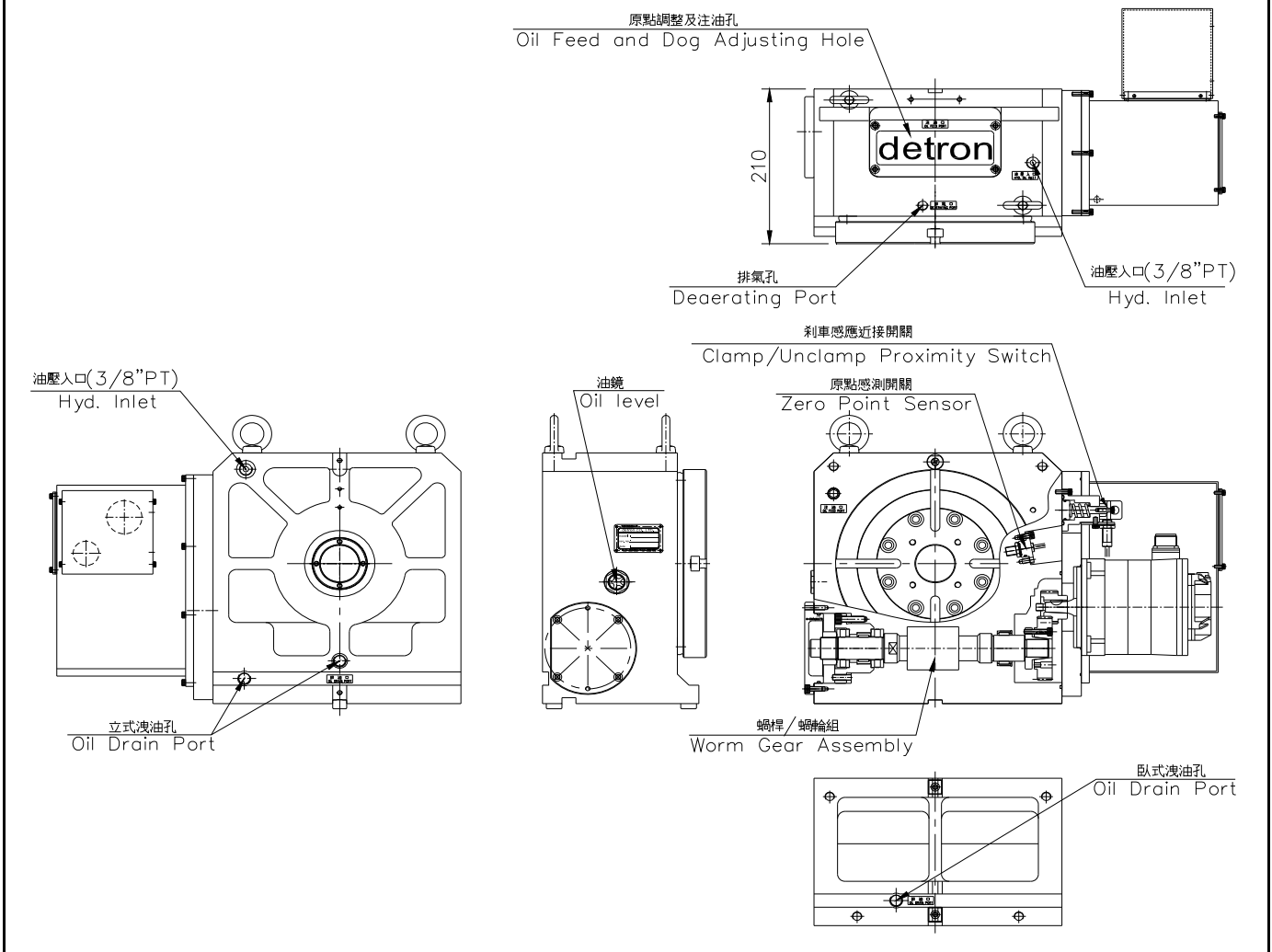

Fig 4-1



* For GX-255HL, the motor cover is at the left of the worktable.

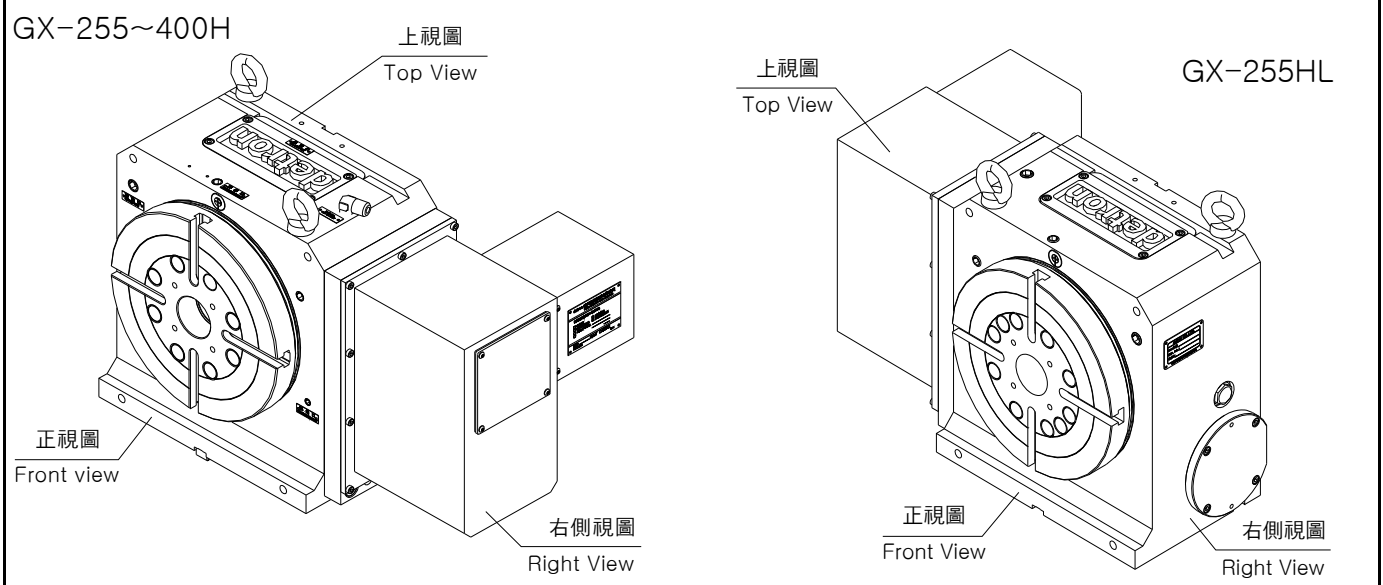

Fig 5-1

detron	5 Mechanism of Main Parts
Title	5.2 GX-500/630/800 Mechanism of Main Parts

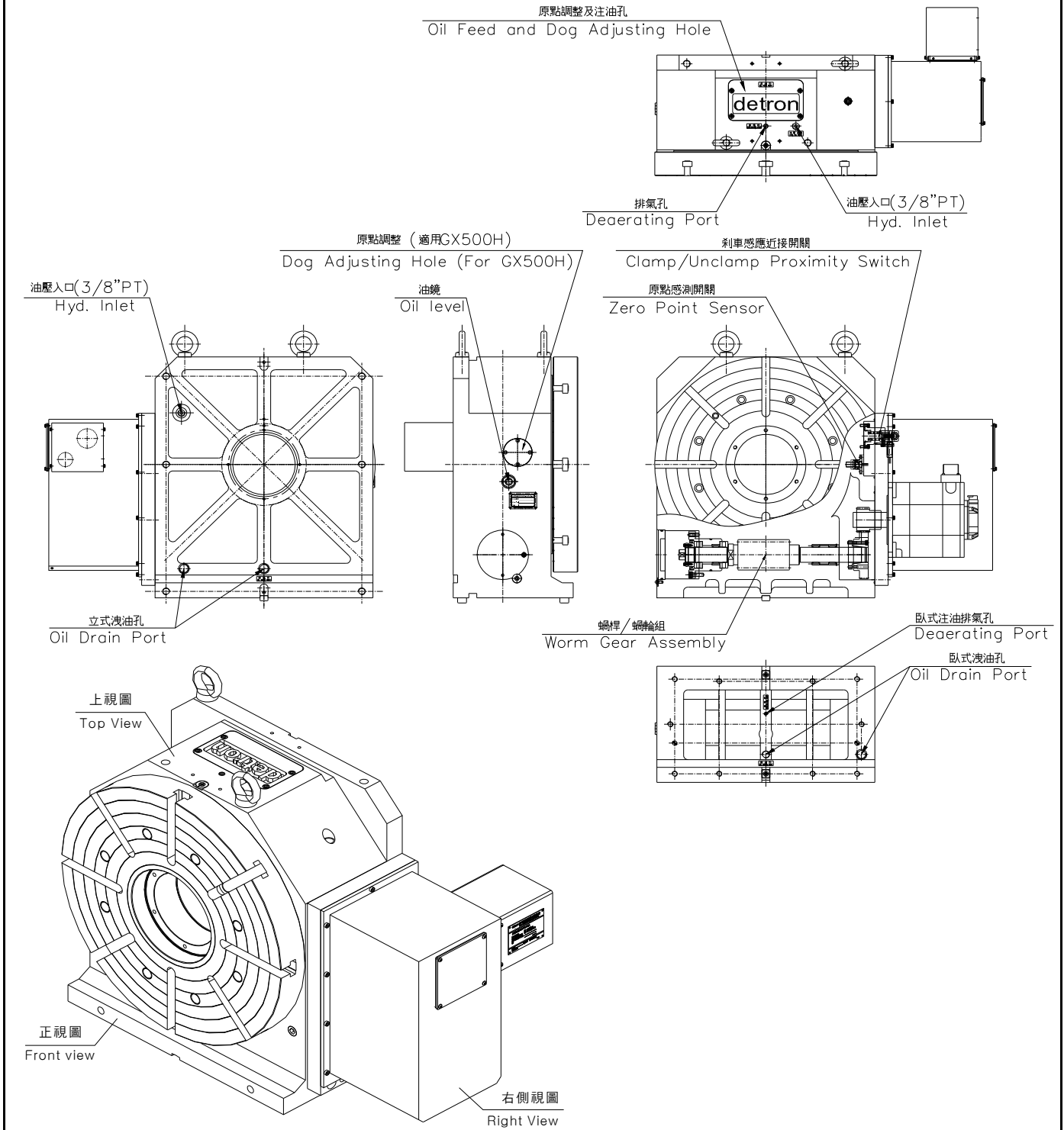

Fig 5-2

detrone	6 Commissioning Procedure
Title	6 Commissioning Procedure

※ Prior to using the rotary table, prepare the machine in the following sequence:

A. Unpacking and preparation

Prior to using and commissioning the rotary table, prepare the follows:

- (1).Unpack and remove the attaching parts from the rotary table.
- (2).Wipe away the grease with a cleaning agent.
(Note : Do not use benzene, gasoline, or diesel which would produce rust.)
- (3).Clean and de-burr the mounting surfaces and the rotary table.
- (4).Mount the rotary table on the machine center. (see Fig 6-2) °
- (5).Add Lubrication. (see Fig 5-1~5-2 · Page 11-1)
- (6).Make sure that the electrical connection between the Rotary Table and the machine controller is well connected according to the attached electrical circuit diagram.
(see **Electronic Circuit Diagram of packing**) (Note : Switch off the main power of the machine center before connecting the electric cables.)
- (7).Supply hydraulic pressure for clamping and to eliminate the air in hydraulic oil.
(see Fig 5-1~5-2 · Page 10-2)(Note: Hydraulic oil needs filtration)
※Hydraulic system backpressure must be under 0.1MPa, to prevent the conditions of not unclamping completely or the extension of unclamping time of the brake mechanism when conducting unclamp command, because above conditions will cause mechanism damage or servo overload shut down.
- (8).Supply compressed air to bring up barotropic fluid inside of motor cover. Tighten the pneumatic adjustable valve by clockwise and then lose this valve by 1/4~1/2 round to release the air (till sound of spout appears and air eject from nozzle). The positive air pressure stays to avoid any humidity accumulated in the cover and prevent damage and corrosion of internal electrical components. (see Fig 6-1)
(Note : Pneumatic source requires a F.R.L. Unit to ensure the suspending particulates are less than 5um)
- (9).Set up rotary table parameters.(see **Parameter Sheet of package**)
- (10). Trial run.
- (11). Set the grid shift amount for machine zero-return. (see **Page 8-2**)

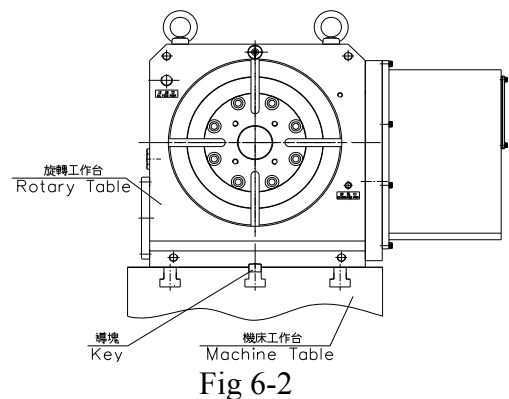
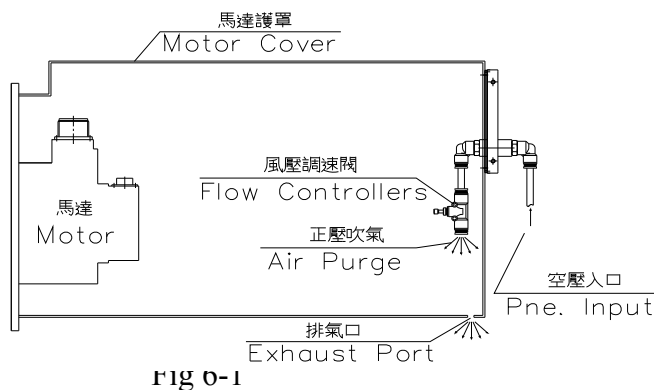

de tr on	6 Commissioning Procedure
Title	6 Commissioning Procedure

B. Trial run

- (1).Make sure both the Rotary table mounting face and plate surface are clean.
- (2).Make sure the Rotary table is load-free.
- (3).Repeat clamp and unclamp functions; test for normal operation.
- (4).Check precision. (*see Inspection Certificate sheet of package*)
- (5).Rotate the CNC Rotary Table clockwise and counter-clockwise about twice at low speed(F300) for the first time, and make sure that the Rotary Table rotates smoothly, then gradually increase the speed up to the rapid speed.
- (6).Perform Zero reset, check for correct return to 0 ° .
- (7).Check different command operations by using NC operation commands.

※ When an unclamp/clamp signal is detected, it is strongly suggested that a 0.5 sec. delay be applied before carrying out the subsequent command to ensure the table has completed the unclamping or clamping action. This is to prevent internal mechanism damage or overload of the servo motor.

※ Never start processing with the Rotary table before completing the above actions, otherwise mechanism damage may occur.

de tr on	7 PLC Flow Chart of Control System
Title	7 PLC Flow Chart of Control System

To make sure detron Rotary tables are under good conditions when operating, please follow below PLC control circuit process for operation. (see Fig 7-1)

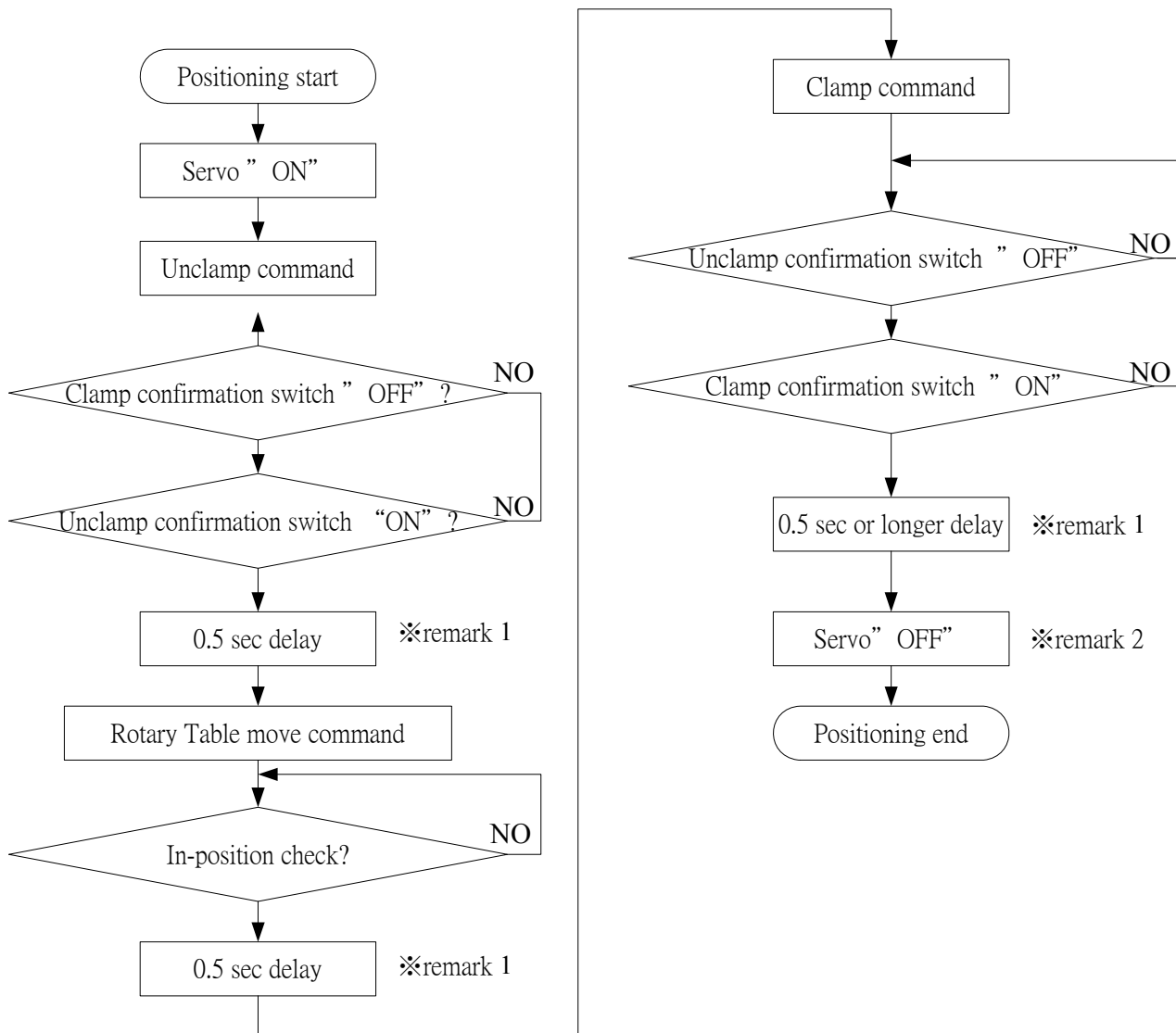

Fig 7-1

※ Remark 1 : Delay time is our recommended time, but actual delay time may differ depending on different rotary table operation conditions.

※ Remark 2 : When the unbalanced load makes a large current (70% or more of the rated current) occur in operation, turn the servo motor OFF. Turn the servo motor OFF as well when applying to full closed loop control.

de tr on	8 Zero Return Adjustment and Grid Shift Amount Setting
Title	8.1 Zero Return Adjustment

Zero Reset of Rotary Table is achieved via detection of proximity switches.

Inactive or false action of proximity switch may be caused by the following conditions:

- Proximity Switch failure.
- Excessive distance between proximity switch and Zero Dog (remove proximity switch bracket, loosen nut and adjust the distance of proximity switch); the optimal distance shall be 1.0~2.0 mm. (*see Fig 8-1*)
- Inaccurate relative position between proximity switch and Zero Dog. Open the cover of observation window, loosen screws on Zero Dog; move Zero Dog to a proper position and test for correct action. Replace the cover of observation window. (*see Fig 5-1~5-2*)

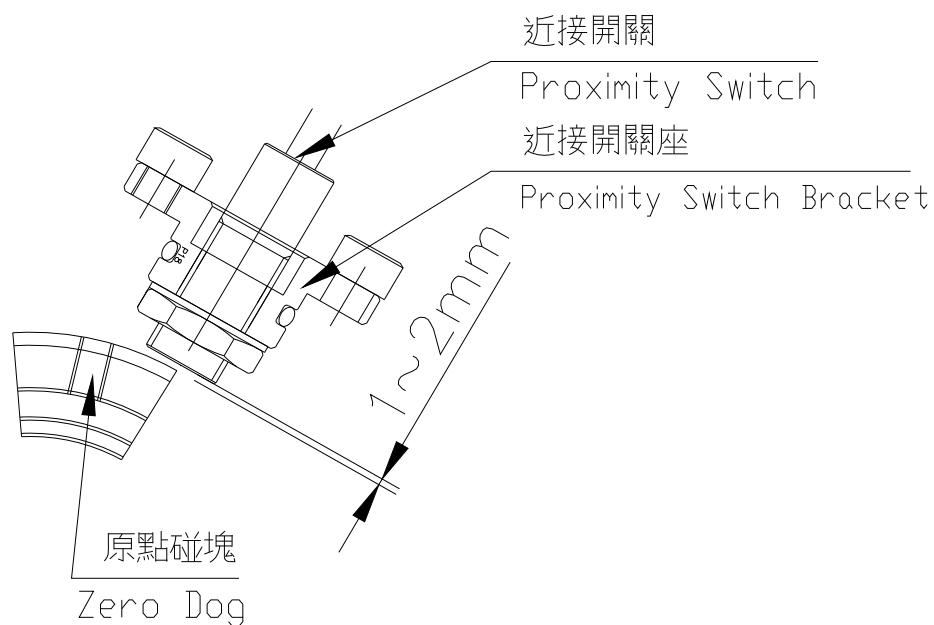

Fig 8-1

Title

8.2 Zero Return Grid Shift Amount Setting

- (1).When the machine receives Zero Reset Command from NC controller, the Rotary Table will start to rotate in the specified forward direction to zero position.
- (2).When the Zero Dog touches the Proximity Switch, Rotary Table starts to decelerate for an accurate and prompt stop.(see Fig 8-3)
- (3).When the Rotary Table reduces its rotation speed, it will stop at Zero when a reference signal from the motor is received.
- (4).Perform turntable operation several times; measure errors between the actual stopping point and nominal stopping point of the Rotary Table. Enter the measurements into Zero Offset of the NC System for correction.

NOTE :

※In general, Zero Return is positioned when face plate T-slot is parallel to the bottom of the body, and the "0" position on the face plate indicates to the zero plate position.(see Fig 8-2)

※If the result is different, the computer parameter needs to be adjusted to achieve parallelism. The correction parameter shall not be of negative value. If a negative value occurs, it means the Zero Dog must be moved forward to a proper position for carrying out parameter adjustment.

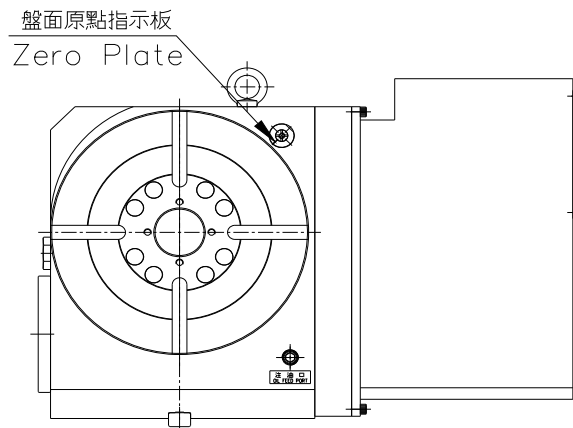

Fig 8-2

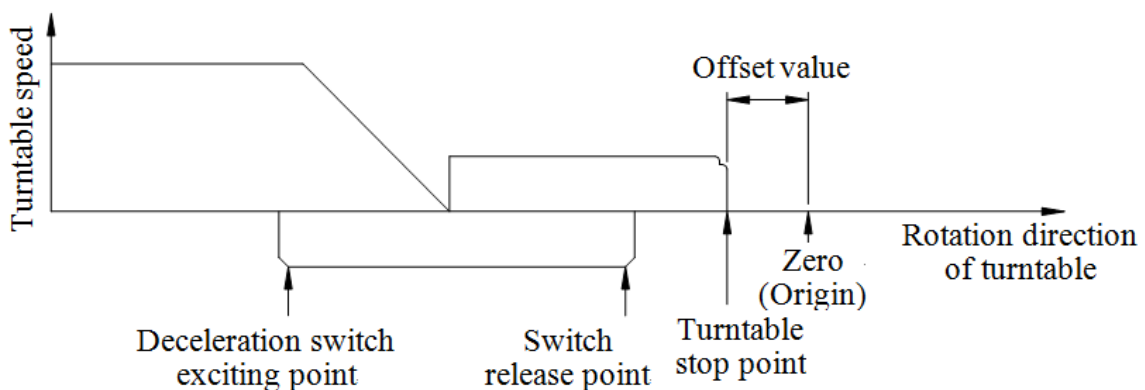

Fig 8-3

Title

9.1 Worm Wheel and Worm Shaft Backlash Inspection

Detron NC Rotary Table is highly reliable and meant for maintenance free. In order to maintain normal conditions for a prolonged period, some adjustments and maintenance are required.

Excessive backlash between the Worm Wheel and the Worm Shaft will cause an undesirable effect between the Worm Wheel and the Worm Shaft when operating the Rotary Table. This not only affects processing accuracy of the work piece, but also directly reduces the service life of both the Worm Wheel and the Worm Shaft. When the backlash between the Worm Wheel and the Worm Shaft is too small, excessive heat may be generated by the Worm Wheel will cause the worm wheel seized. In order to maintain long-term operation of the machine, the proper gap between the Worm Wheel and the Worm Shaft must be checked periodically. (see Page 9-1)

《Inspection Procedure》 (see Fig 9-1)

- (1). Make sure that braking mechanism of the measuring axis is in released state, and the servomotor is in the OFF state.
- (2). Place dial gauge pin on the inner side of the T-slot.
- (3). Place a steel plate into the T-slot of face plate.
- (4). Slowly turn the face plate manually by using the steel plate, exert a 15 to 20 kg force clockwise or counter clockwise; release the force immediately after exerting it, allow the gauge to resume a steady reading. Followed by doing the same in the reverse direction and read the reading. The difference between two readings of the dial gauge is the value of the gap between gears.
- (5). Method for measuring the backlash: Take 4 points on the Worm Wheel in 90° intervals (Rotary Table rotation angle). Make one measurement every 90° and take the average.
- (6). At 20°C environmental temperature, the proper backlash between the Worm Wheel and the Worm Shaft should be 10 to 15 seconds. Adjustment is required if otherwise.

※Based on thermal expansion principle, this backlash value should be properly adjusted in accordance with surrounding temperatures.

※Room temperature for using the rotary table : $5^\circ\text{C} \sim 40^\circ\text{C}$.

The turntable is still operable even when the backlash exceeds the upper limit listed above. When a backlash adjustment is required, and the backlash correction value is entered into the NC Unit by using parameter methods, then the backlash value becomes 0.

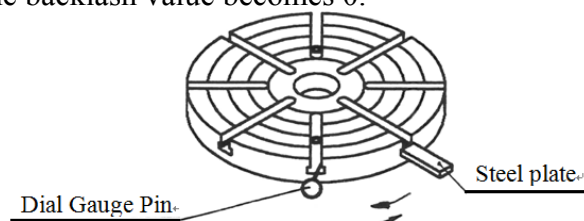

Fig 9-1

Title 9.2 Worm Wheel and Worm Shaft Backlash Adjustment

※ Adjusting an excessive backlash(see Fig 9-2)

- (1).Evenly loosen the Adjusting Screw 1/2 turns counterclockwise.
- (2).Evenly tighten the Locking Screw clockwise. This makes the worm shaft axis move forward to reduce the backlash.
(The order to tighten the Locking Screw : L1->L2->L3->L4->L5->L6)
- (3).Measure the backlash as described on the previous page.(see Page 9-1)
- (4). Based on the measurement, adjust the Adjusting Screw repetitively until the standard backlash value is reached. (see Page 9-1)

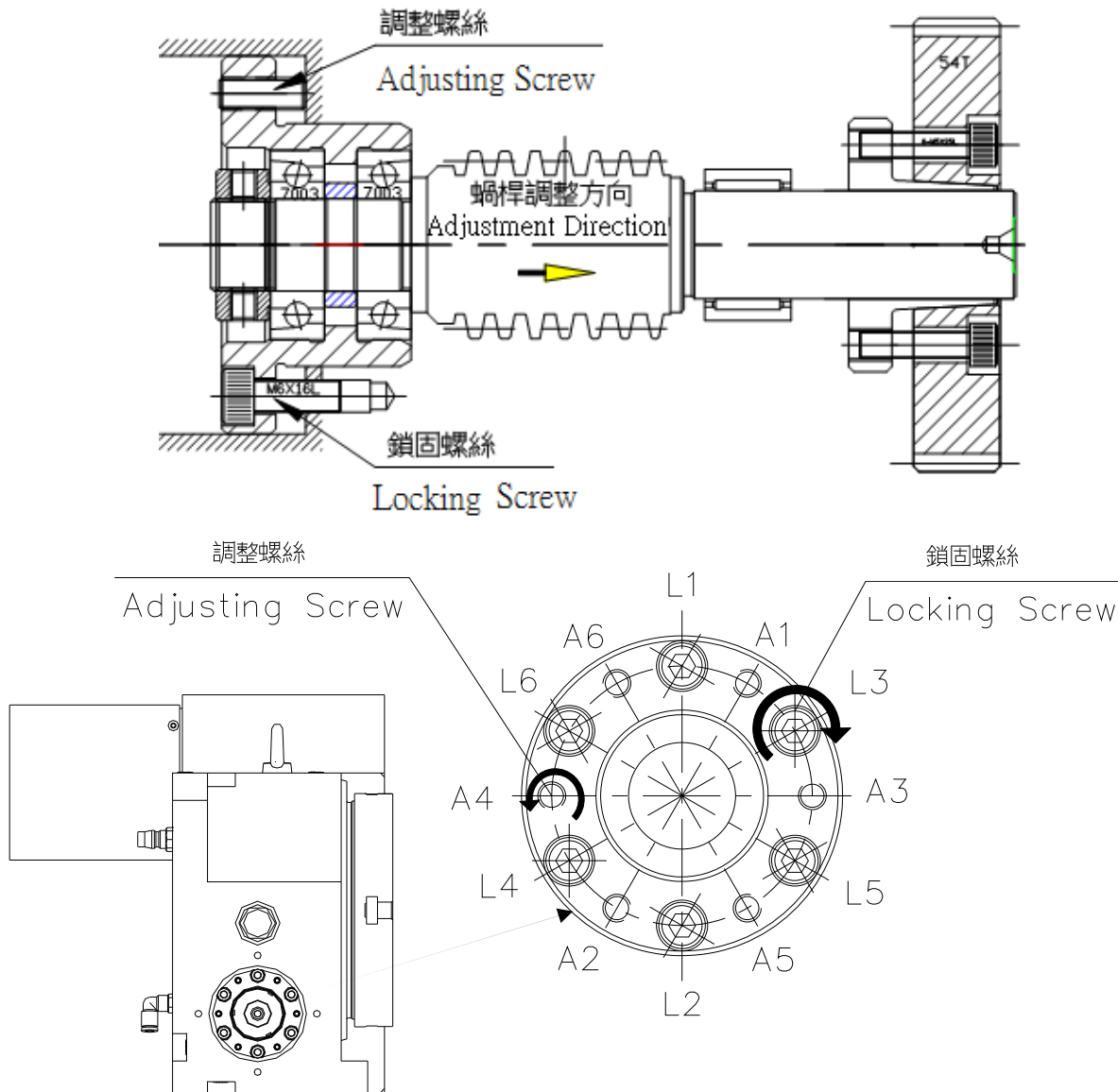

Fig 9-2

Title 9.2 Worm Wheel and Worm Shaft Backlash Adjustment

※ Adjusting an insufficient backlash(see Fig 9-3)

- (1).Evenly loosen the Locking Screw 1/2 turns counterclockwise.
- (2). Evenly tighten the Adjusting Screw. This makes the worm shaft axis move backward to reduce the backlash.
(The order to tighten the Adjusting Screw : A1->A2->A3->A4->A5->A6)
- (3).Evenly tighten the Locking Screw clockwise.
(The order to tighten the Locking Screw : L1->L2->L3->L4->L5->L6)
- (4).Measure backlash as described on the previous page. (see Page 9-1)
- (5).Based on measurement, adjust the Adjusting Screw repetitively until the standard backlash value is reached. (see Page 9-1)

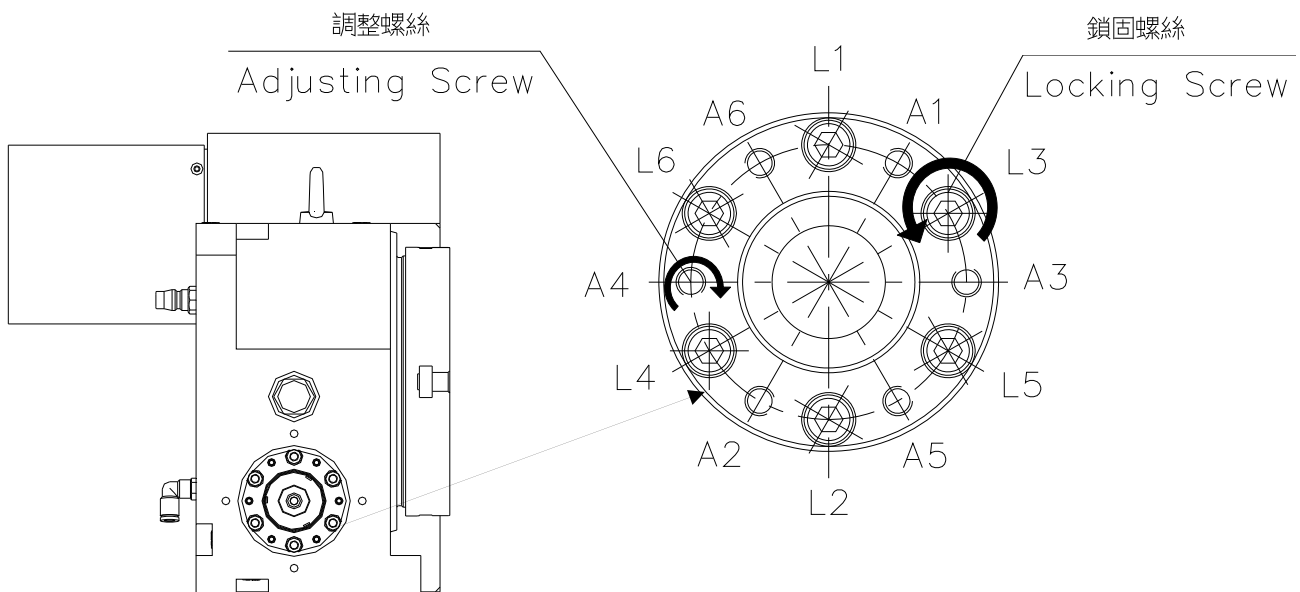
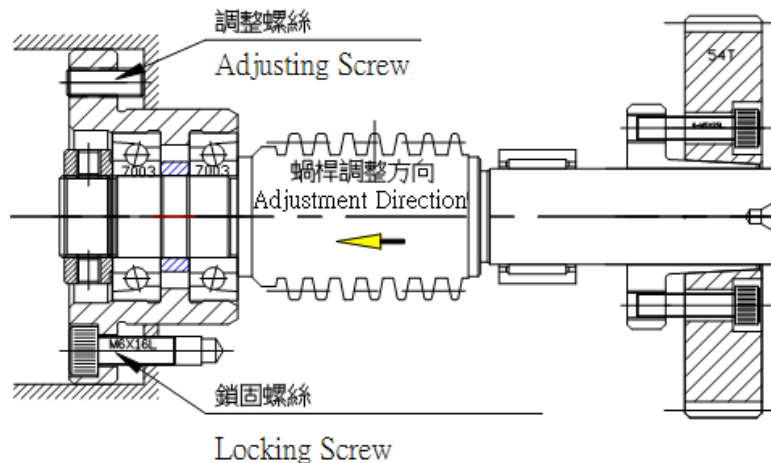

Fig 9-3

Title 9.3 Transmission Gear Backlash Adjustment

※ **Adjusting Backlash of the Gear**(see Fig 9-4)

- (1).Remove the Motor Cover.
- (2).Loosen the Motor Adapter Locking Screw.
- (3).Push Motor Adapter downward, so that there is no backlash between motor gear teeth and the Worm Shaft.
- (4).Place dial gauge on the body.
- (5).Adjust gear center distance in the arrow direction (backlash increases when Motor Adapter moves up, decreases when Motor Adapter moves down).
- (6).Standard backlash.

Model	GX-255	GX-320	GX-400	GX-500/630/800
Backlash (Dimensional unit : mm)	0.04 ~ 0.052	0.032 ~ 0.042	0.04 ~ 0.05	0.044 ~ 0.058

- (7).Tighten Motor Adapter Locking Screws.
- (8).Replace the Motor Cover.

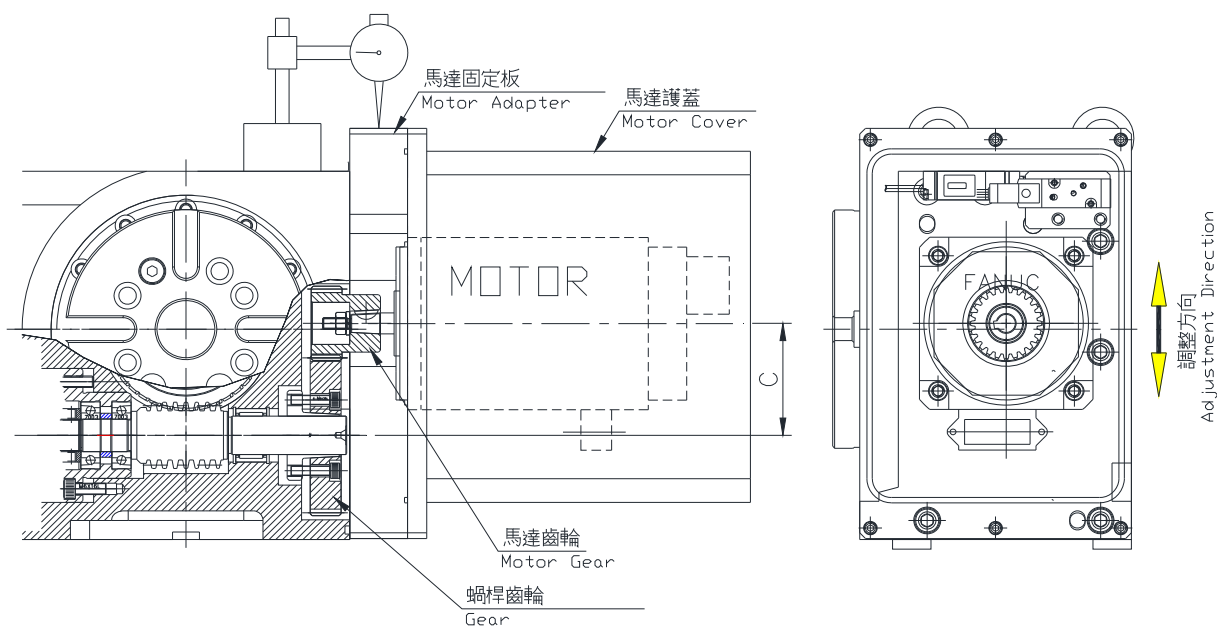

Fig 9-4

de t ron	10 Clamp/Unclamp Device
Title	10 Clamp/Unclamping Device
<p>After placing a work piece, make sure to tighten the rotary table. Processing without tightening the rotary table will cause quick wear or damage of the worm wheel as well as tool and work piece damage. When adjusting the angle of the rotary table or performing continuous cutting, always confirm that the rotary table is in the released state. To ensure the correct state, always check the Clamp/Unclamp signal for correct indication.</p> <p>In order to achieve proper clamp torque, the rotary table requires 5MPa hydraulic pressure(GX-800H is 3.5MPa); when applying a lower pressure, clamping torque will be decreased accordingly, two connection terminals (3/8"PT) are provided with the product, at the top and the rear, select one for use.</p> <p>After receiving clamping command, hydraulic oil flows to the drum brake, drum brake will clamp the rotary table evenly, so that the rotary table can reach the best and accurate clamping torque. When receiving unclamping command, hydraulic oil will be released, the brake pressure disappears and the drum brake returns it's original form, so that the rotary table will be under unclamping condition.</p> <ul style="list-style-type: none"> ※ While the hydraulic oil flows to the drum brake, it also flows to related mechanism for showing unclamp/clamp of the rotary table. At the time in clamp, the dog activating piston (when hydro-oil acting the piston) shift upwards, the proximity switch (LS51) shows the rotary table is clamped. At the time in unclamp, the dog activating piston shift downwards, the proximity switch (LS52) shows the rotary table is unclamped. ※ When mechanism switch clamping, the actuating pressure is more than 1~1.2MPa. ※ When using pressure switch for unclamping/clamping, the actuating pressure range is 1.8~2.2MPa. ※ When hydraulic oil is mixed with air, the clamping torque can't reach the expected performance; then we need to exhaust the air. Please follow the instruction below: <ol style="list-style-type: none"> (1). Adjust the oil pressure to 2MPa (to prevent the mass oil spilling over the hole). (2). Loosen the bolts on the top of the body for 1/4~1/2 loop. (for GX-255H, please remove the bolt before step(2)) (<i>see Page 5-1~5-2</i>) (3).Repeat unclamp and clamp commands, then the hydraulic oil mixed with air will drain out. Till the oil draining out is no longer with air, tighten the bolts, the air exhausting process is completed. ※ Hydraulic system backpressure must be under 0.1MPa, to prevent the conditions of not unclamping completely or the extension of unclamping time of the brake mechanism when conducting unclamp command, because above conditions will cause mechanism damage or servo overload shut down. ※ When an unclamp/clamp signal is detected, it is strongly suggested that a 0.5sec. delay be applied before carrying out the subsequent command, to ensure the table has completed the unclamping or clamping condition. This is for preventing internal mechanism damage or overload of the servo motor. 	

Lubricant is a key factor to performance and service life of your machine. Always use lubricants recommended in the manual.

Model	GX-255	GX-320	GX-400	GX-500	GX-630/800
Oil quantity required in machine body Unit: Liter	2	3.2	4.2	5.5	10.0

※ Precautions for replenishing and replacing lubricant.

(1) Selection of lubricant is based on several features :

- a. The Oil film strength, rust resistance and oxidation resistance.
- b. The viscosity class shall be within ISO-VG100~150.

※ Since lubricants engulf the Worm Wheel, Worm Shaft and other respective parts, quality products must be used to ensure satisfactory operation.

※ Recommended Ambient Temp. range is 18°C~40°C under normal usage, Contact Lubricant mfg for suggested lubricant product if the temp. is higher or lower than the recommended range.

mfg	Product
Shell	Omala 150
Esso	Spartanep 150
Mobile	Mobile Gear 629
JoMo	Reductus 100

(2) Pay attention to keep the lubricant clean; always clean up auxiliary tools for replenishing oils. Never allow external dust and debris entering the oil tank.

(3) DO NOT mix lubricants of different brands since their ingredients are different; mixed use may impair lubrication properties.

(4) Replenish the oil to the centerline of the oil level window.

(see Fig 5-1~5-2 for oil level position).

(5) Replace the lubricant every 6 months or after 1200hr operation; check oil amount from time to time and replenish as necessary.

Title

12 Troubleshooting

No.	Symptom	Cause	Check	Solution
1	Turntable not turning (1) Motor not running	* Cable damage	*Check cable and end connections	* Refer to electric circuit diagram
	(2) Motor idle running	*Tapered sleeve slackened	*Check all gears	* Fix again
2	Turntable runs not smoothly	* Overload	* Check load and gyration inertia * Check motor operation at that time * Check operation condition at low-speed.	* Reduce the load or stop processing this workpiece
3	Noise when rotating	*Faulty fixation of gears in gear box * Incorrect lubrication * Slackened operation (Residual hydraulic pressure) * Damaged worm wheel, worm shaft or gear in gear box	*Check equipment condition *Check lubricant type and quantity * Check clamp part and turntable clamps (Slackened) pressure switch control	*Re-calibrate *Replenish or replace lubricant * Calibrate tooth face or replace gear
4	Motor over-current	* Faulty zero offset	* Over current only when tightened	* Re-do zero offset
		* Overload operation * Backlash of worm wheel and worm shaft too small or uneven * Insufficient warm-up time or incorrect parameter setting	* Check load * Check backlash *Check program	* Alter load or loading method *Adjust backlash * Revise program
5	Inaccuracy (1) Poor division precision	*Insufficient Hyd. pressure *Incorrect solenoid valve spec. * Pipeline clogged * Worm Wheel face worn out	*Check pressure *Check solenoid valve spec. *Check solenoid valve condition *Check pipeline * Measure backlash	*Adjust pressure * Replace with correct solenoid valve spec. * Replace solenoid valve * Replace pipeline *Adjust backlash
	(2) face plate face undulation or center sway	*Slackened nut of shaft bearing	*Compare with precision tolerance	*Contact detron or dealer
6	Clamp/Unclamp operation (1)No Clamp/Unclamp signal	*Signal line connection defect * Improper adjustment of switch equipment *Pressure switch damaged	*Check signal cable	*Re-adjust *Replace pressure switch
	(2) Delayed signal output	* Hydraulic filter screen clogged * Insufficient hydraulic pressure	*Check filter screen *Check pipeline for clog or fracture *Check hydraulic pressure supply system for normal operation	*Replace pipeline
7	Clicking sound in cutting operation. (1)When starting to cut after emplacing workpiece	* External force * Clamping action	*Check cutting condition *Check tightening tool and turntable clamp (or unclamp) pressure switch	*Correct cutting condition *Adjust backlash
	(2) In continuous cutting	* Excessive worm wheel backlash * Poor teeth engagement	* Measure gear backlash	*Adjust backlash

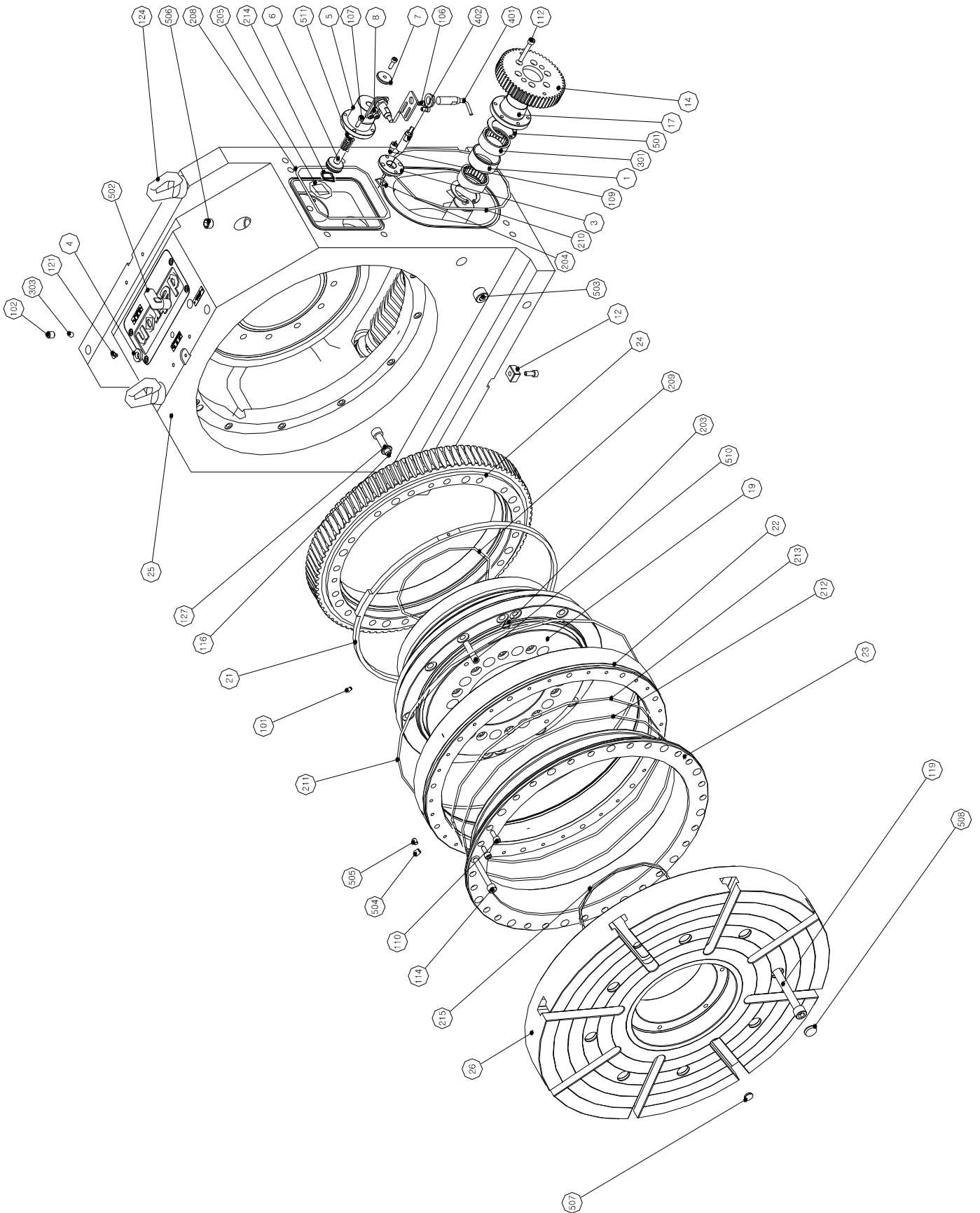

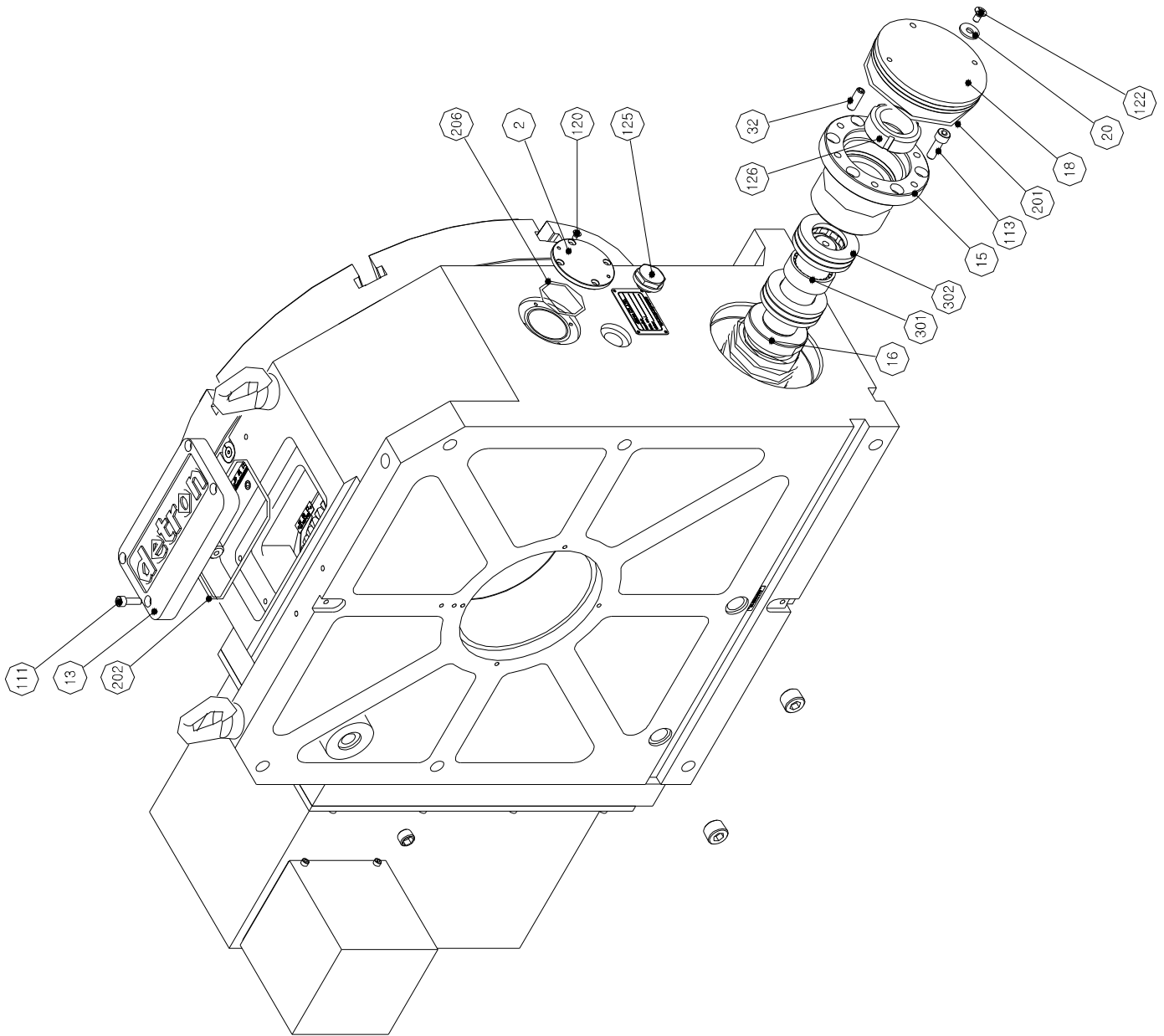

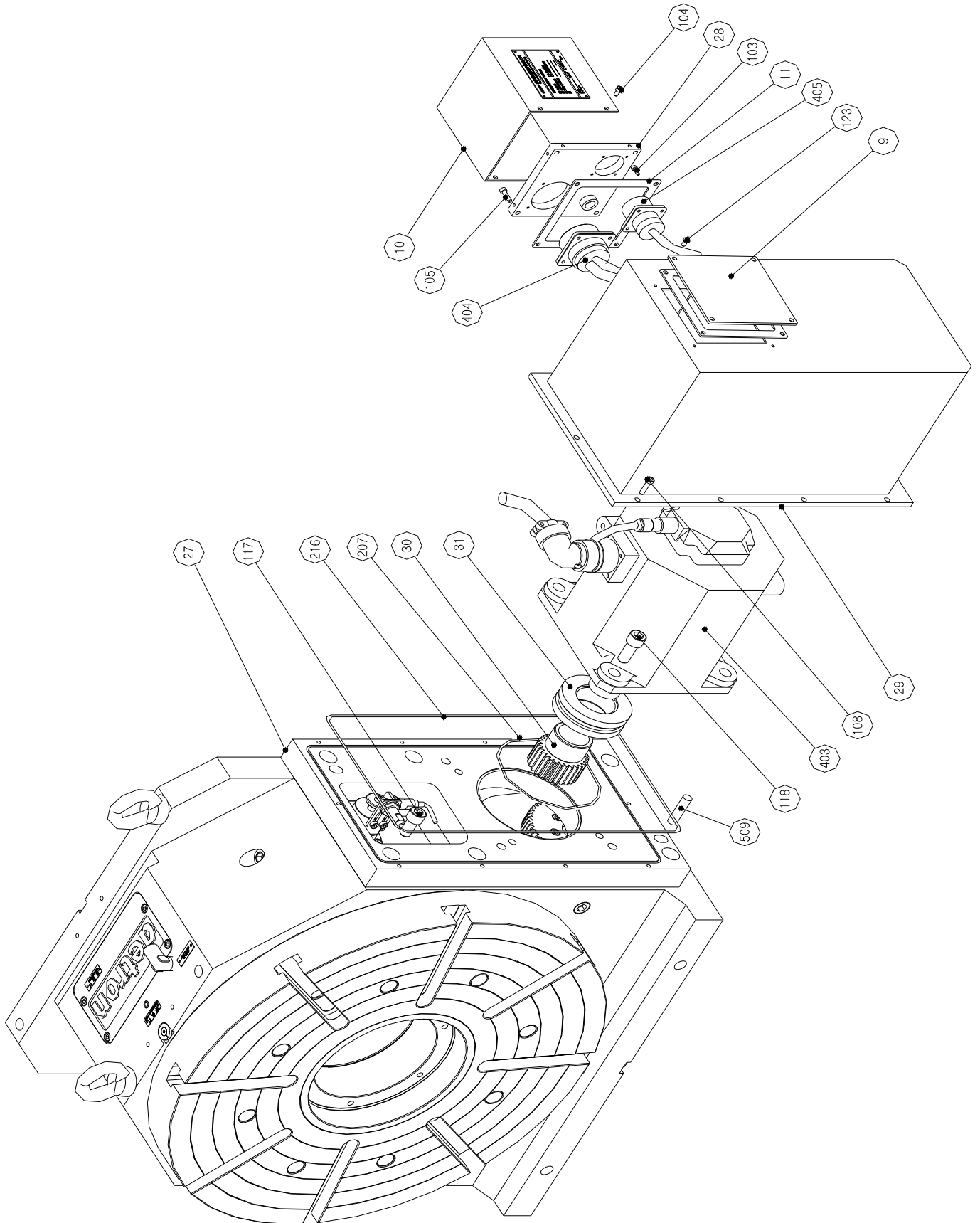

detrone		13 Parts List			
Title		13 Parts List			
No.	Part No.	Chinese	English	Q'ty	Spec.
1	GH501N0033A	軸承間隔環	Spacer	1	
2	GX125N0041B01	觀視窗蓋	Cover	1	
3	GX170N0030A01	原點近接開關座	Proximity switch bracket	1	
4	GX255N0037B	盤面原點指示板	Home indicator	1	
5	GX320N0046B	油缸	Cylinder	1	
6	GX320N0047A	活塞	Piston	1	
7	GX320N0048A	煞車感應環	Ring	1	
8	GX320N0049B	近接開關固定座	Proximity switch bracket	2	
9	GX320N0052A	蓋板	Cover	1	
10	GX320N0054C01	軍規接頭護蓋	Cover	1	
11	GX320N0056B	軍規接頭轉接蓋板膠皮	Rubber for cover	2	
12	GX320N0058C	鍵	Key	2	
13	GX320N0090B02	上封蓋	Cover	1	
14	GX400N0029B02	蝸桿齒輪	Gear	1	
15	HH400N0036B	調整側套管	Sleeve of worm shaft	1	
16	HH400N0057D01	蝸桿	Worm shaft	1	
17	GX400N0030A02	齒輪壓蓋	Fasten ring	1	
18	HH400N0048A01	蝸桿封蓋	Cover	1	
19	GX500A0002A	主心軸組	Main spindle set	1	
20	HH630N0038A	原點調整封蓋壓板	Cover	1	
21	GX500N0022B01	原點碰塊	Home dog	1	
22	GX500N0030A02	煞車外環	Brake outer ring	1	
23	GX500N0031A02	煞車內環	Brake inner ring	1	
24	GX500N0037B01	蝸輪	Worm wheel	1	
25	GX500NW001G01	本體加工圖	Body	1	
26	GX500NW002C02	盤面加工圖	Table plate	1	
27		馬達調整板	Motor plate	1	
28		軍規接頭轉接蓋板	Plate of connection	1	
29		馬達護蓋	Cover	1	
30		馬達齒輪	Gear	1	
31		迫緊環	Expansion clamping set	1	
32	GX255N0061A	無頭螺絲	Set screw	6	

