

# *GX-125~210 Series*

## **CNC Rotary Table**

- |                                   |                                   |   |
|-----------------------------------|-----------------------------------|---|
| <input type="checkbox"/> GX-125P  | <input type="checkbox"/> GX-170P  | <input type="checkbox"/> GX-210P            |
| <input type="checkbox"/> GX-125PL | <input type="checkbox"/> GX-170PL | <input type="checkbox"/> GX-210PL           |
|                                   | <input type="checkbox"/> GX-170H  | <input type="checkbox"/> GX-210H            |
|                                   | <input type="checkbox"/> GX-170S  | <input checked="" type="checkbox"/> GX-210S |

## **Operation Manual**

detron machine co., LTD.

<http://www.detron.com.tw> e-mail: [sales@detron.com.tw](mailto:sales@detron.com.tw)

[export.sales@detron.com.tw](mailto:export.sales@detron.com.tw)

No. 47-5, Zuncian Road, Shengang District 42952, Taichung City, Taiwan

TEL:886-4-2561-6000 FAX:886-4-2562-7872

# Table of Contents



<b>1</b>	<b>Introduction</b> .....	<b>1-1</b>
<b>2</b>	<b>Specifications</b> .....	<b>2-1</b>
2.1	GX125/170 Specifications.....	2-1
2.2	GX210 Specifications.....	2-2
<b>3</b>	<b>Dimensional Drawing</b> .....	<b>3-1</b>
3.1	GX125P/PL Dimensional Drawing.....	3-1
3.2	GX170~210P/PL/H Dimensional Drawing.....	3-2
3.3	GX170/210S Dimensional Drawing.....	3-3
<b>4</b>	<b>Circuit Diagram</b> .....	<b>4-1</b>
4.1	Pneumatic Circuit Diagram.....	4-1
4.2	Hydraulic Circuit Diagram.....	4-2
<b>5</b>	<b>Mechanism of Main Parts</b> .....	<b>5-1</b>
5.1	GX-P/PL/S Series Mechanism of Main Parts.....	5-1
5.2	GX-170/210H Mechanism of Main Parts.....	5-2
<b>6</b>	<b>Commissioning Procedure</b> .....	<b>6-1</b>
<b>7</b>	<b>PLC Flow Chart of Control System</b> .....	<b>7-1</b>
<b>8</b>	<b>Zero Return Adjustment and Grid Shift Amount Setting</b> .....	<b>8-1</b>

8.1	Zero Return Adjustment.....	8-1
8.2	Zero Return Grid Shift Amount Setting.....	8-2
<b>9</b>	<b>Backlash Adjustment.....</b>	<b>9-1</b>
9.1	Worm Wheel and Worm Shaft Backlash Inspection.....	9-1
9.2	Worm Wheel and Worm Shaft Backlash Adjustment.....	9-2
9.3	Transmission Gear Backlash Adjustment.....	9-4
<b>10</b>	<b>Clamp/Unclamp Device.....</b>	<b>10-1</b>
10.1	Pneumatic Clamp/Unclamp Device.....	10-1
10.2	Hydraulic Clamp/Unclamp Device.....	10-2
<b>11</b>	<b>Lubrication Replacement.....</b>	<b>11-1</b>
<b>12</b>	<b>Troubleshooting.....</b>	<b>12-1</b>

detron	<b>1 Introduction</b>
<b>Title</b>	1 Introduction

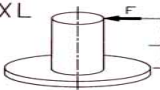

Welcome to detron, thank you for purchasing our CNC Rotary Table. This manual provides important information and detailed instruction for operating and maintaining the machine. We suggest that you peruse the manual thoroughly before operating to ensure optimal conditions of the machine and to effectively prolong its service life.

Keep this manual for convenient consultation.

de <b>tron</b>		2 Specifications				
Title		2.1 GX125/170 Specifications				
No.	Item	Unit	GX125P/PL	GX170P/PL/H	GX170S	
1	Worktable diameter	mm	Ø125	Ø170	Ø170	
2	Center bore diameter	mm	Ø30H7	Ø40H7	Ø40H7	
3	Through- hole diameter	mm	Ø25	Ø40	Ø40	
4	Height of center	Vertical	mm	110	135	135
5	Height of table	Horizontal	mm	155	158	174
		Vertical (※Remark 1)	mm	261.5	292	292
6	Width of T-slot	mm	12H7	12H7	12H7	
7	Width of guide block	mm	18	18	18	
8	Drive pressure / method	MPa	0.5~0.7(Pne.)	0.5~0.7(Pne.)/2.5(Hyd.)	0.5~0.7(Pne.)	
9	Clamping torque	N · m	80	180(Pne.)/240(Hyd.)	300	
10	Servo motor type (※Remark 2)	FANUC		α2i	α4i	α4i
		mitsubishi		HF75T	HF54T	HF54T
		SIEMENS		1FK7042	1FK7060	1FK7060
		HEIDENHAIN		QSY96A	QSY116C	QSY116C
		YASKAWA		SGMJV04A	SGMGV09A	SGMGV09A
11	Transmission ratio		1/90	1/90	1/90	
12	Max. table speed	min <sup>-1</sup>	44.4	44.4	44.4	
13	Allowable loading inertia	Kg · m <sup>2</sup>	0.2	0.55	0.55	
14	Resolution	deg.	0.001	0.001	0.001	
15	Indexing accuracy	sec	40	20	20	
16	Repeatability	sec	6	6	6	
17	Net weight (servo motor excluded)	Kg	35	54	52	
18	Allowable loading capacity	Vertical	Kg	50	75	75
		Horizontal	Kg	100	150	150
		Tailstock applied	Kg	100	150	150
19	Allowable load (when table clamped)		N	9700	14000	14000
			N · m	410	1020	1020
			N · m	80	180(Pne.)/240(Hyd.)	300
20	Allowable wheel torque		N · m	85	170	170

※Remark 1 : Vertical table height excluding eye bolt.

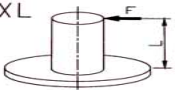
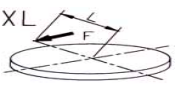
※Remark 2 : Other motor brands available, but the motor cover may be varied as the brand differs.

de <b>tron</b>		<b>2 Specifications</b>			
Title		2.2 GX210 Specifications			
No.	Item		Unit	GX210P/PL/H	GX210S
1	Worktable diameter		mm	Ø210(Ø255 OPT.)	Ø210
2	Center bore diameter		mm	Ø40H7	Ø40H7
3	Through- hole diameter		mm	Ø40	Ø40
4	Height of center	Vertical	mm	160	160
5	Height of table	Horizontal	mm	158 / 186(For dia. 255)	174
		Vertical (※Remark 1)	mm	292	284
6	Width of T-slot		mm	12H7	12H7
7	Width of guide block		mm	18	18
8	Drive pressure / method		MPa	0.5~0.7(Pne.)/2.5(Hyd.)	0.5~0.7(Pne.)
9	Clamping torque		N · m	260(Pne.)/300(Hyd.)	400
10	Servo motor type (※Remark 2)	FANUC		α4i	α4i
		mitsubishi		HF54T	HF54T
		SIEMENS		1FK7060	1FK7063
		HEIDENHAIN		QSY116C/QSY116E(For dia. 255)	QSY116C
		YASKAWA		SGMGV09A	SGMGV09A
11	Transmission ratio			1/90	1/90
12	Max. table speed		min <sup>-1</sup>	44.4	44.4
13	Allowable loading inertia		Kg · m <sup>2</sup>	0.84	0.84
14	Resolution		deg.	0.001	0.001
15	Indexing accuracy		sec	20	20
16	Repeatability		sec	6	6
17	Net weight (servo motor excluded)		Kg	57/66(For dia. 255)	57
18	Allowable loading capacity	Vertical	Kg	75	75
		Horizontal	Kg	150	150
		Tailstock applied	Kg	150	150
19	Allowable load (when table clamped)		N	14000	14000
			N · m	1020	1020
			N · m	260(Pne.)/300(Hyd.)	400
20	Allowable wheel torque		N · m	260	260

※Remark 1 : Vertical table height excluding eye bolt.

※Remark 2 : Other motor brands available, but the motor cover may be varied as the brand differs.

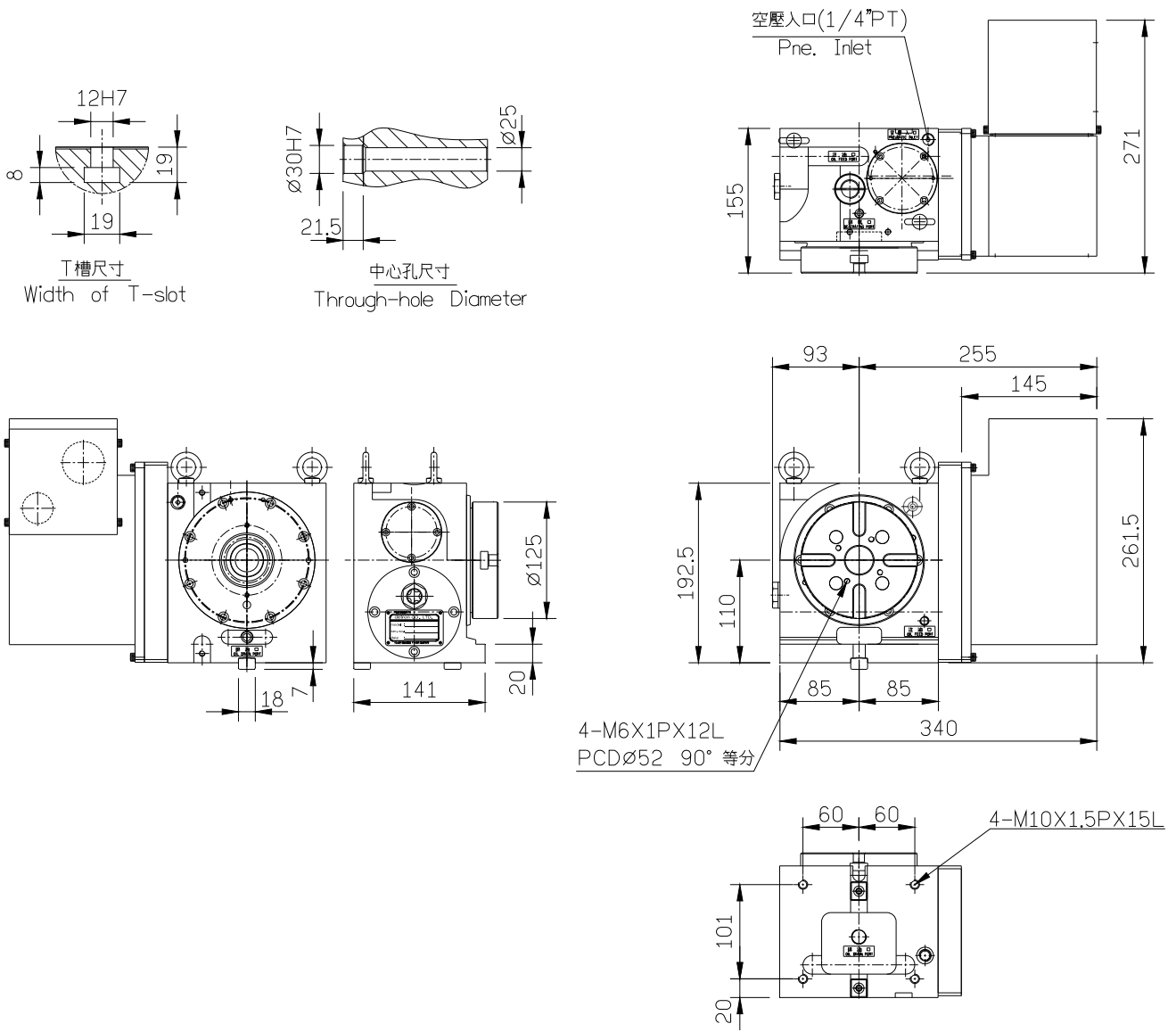

\* Dimension Unit: mm

\* For GX-PL series, the motor cover is at the left of the worktable.

Fig 3-1

**Title** 3.2 GX170~210P/PL/H Dimensional Drawing

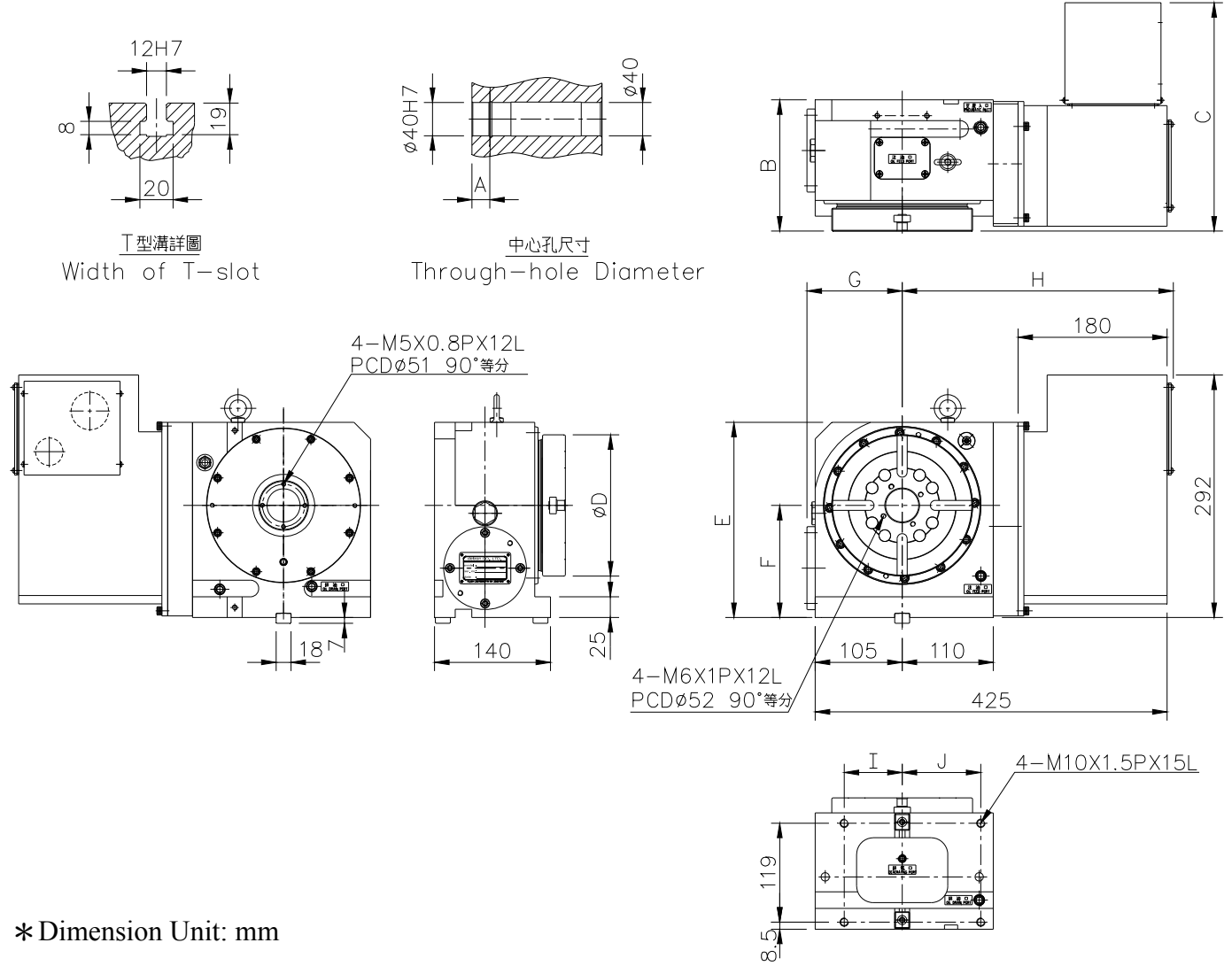

\* Dimension Unit: mm

\* For GX-PL series, the motor cover is at the left of the worktable.

Dimensions and Model	Dimensions Code No.									
	P/PL/H Model	A	B	C	D	E	F	G	H	I
GX170	21.5	158	276	170	235	135	115	327.6	70	95
GX210	21.5	158	276	210	268	160	115	329	72	93
GX210 (For dia. 255)	49.5	186	304	250	268	160	127.5	329	72	93

Fig 3-2

de**tron** **3 Dimensional Drawing**

**Title** 3.3 GX170/210S Dimensional Drawing

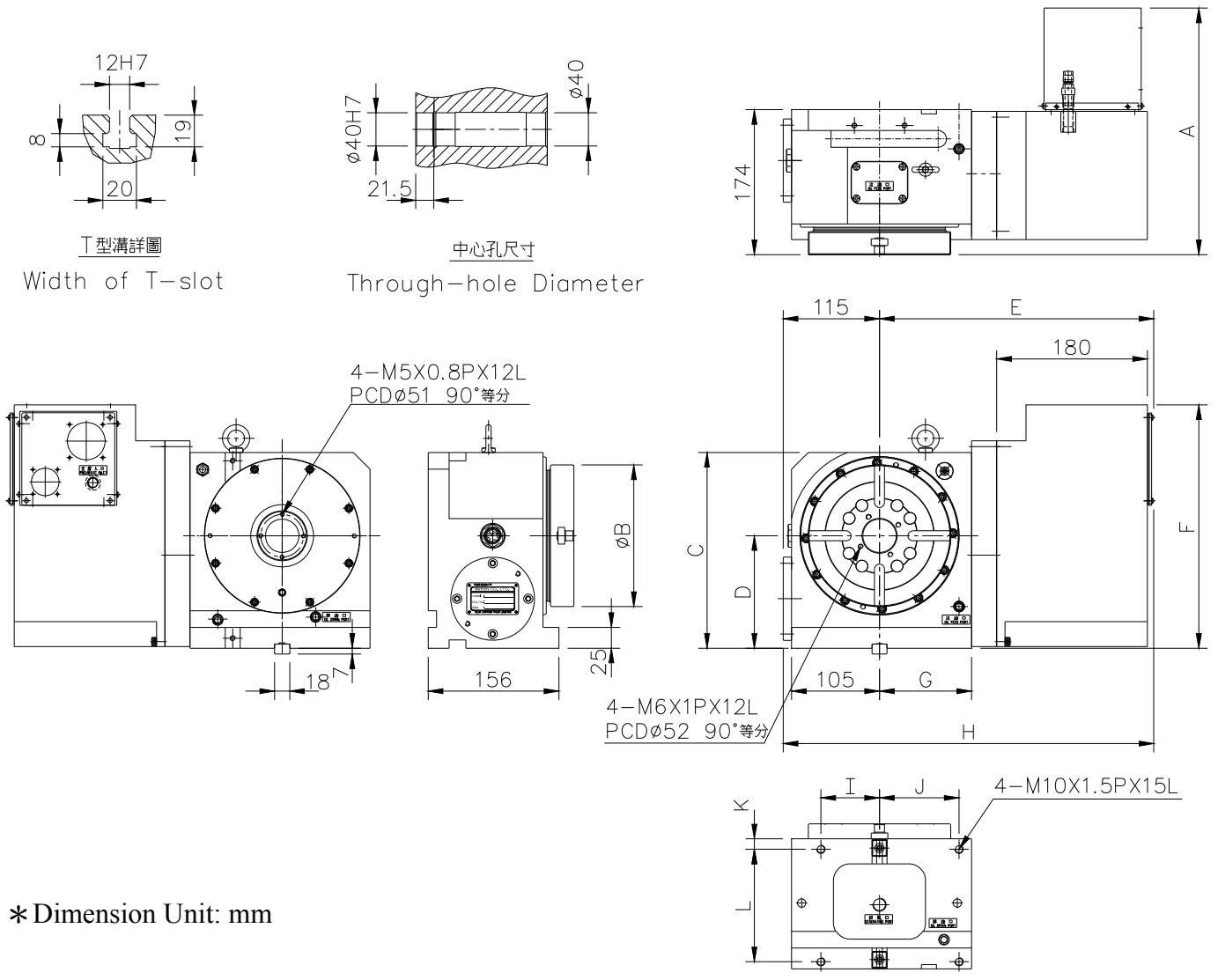

Dimensions and Model	Dimensions Code No.											
	A	B	C	D	E	F	G	H	I	J	K	L
S Model												
<b>GX170</b>	<b>297</b>	<b>170</b>	<b>235</b>	<b>135</b>	<b>327.6</b>	<b>292</b>	<b>110</b>	<b>442.6</b>	<b>70</b>	<b>95</b>	<b>12.5</b>	<b>135</b>
<b>GX210</b>	<b>298</b>	<b>210</b>	<b>270</b>	<b>160</b>	<b>332.6</b>	<b>284</b>	<b>115</b>	<b>447.6</b>	<b>90</b>	<b>85</b>	<b>25</b>	<b>118</b>

Fig 3-3

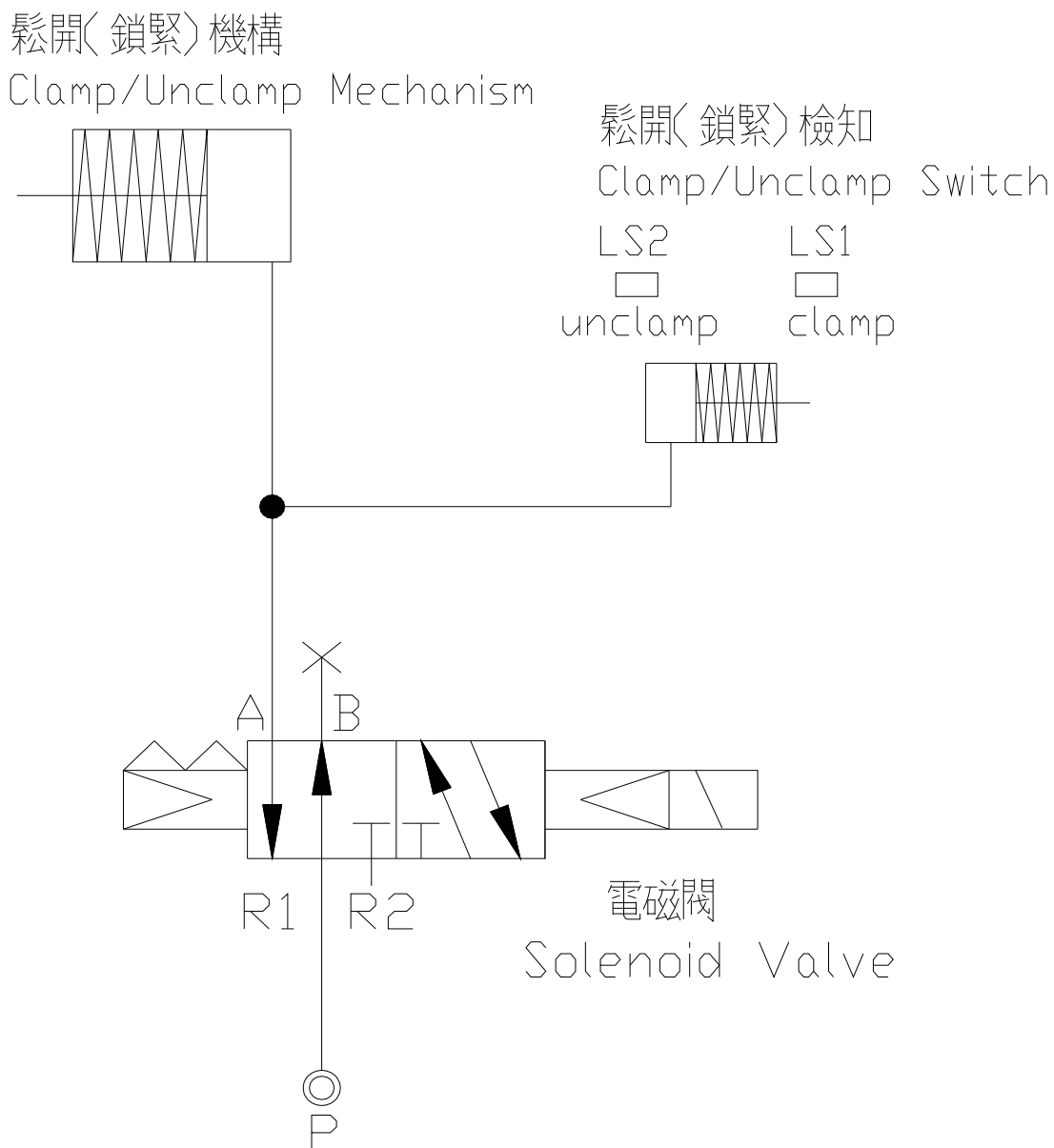

※電磁閥送電鎖緊

Table clamped when Solenoid Valve "ON"

Fig 4-1

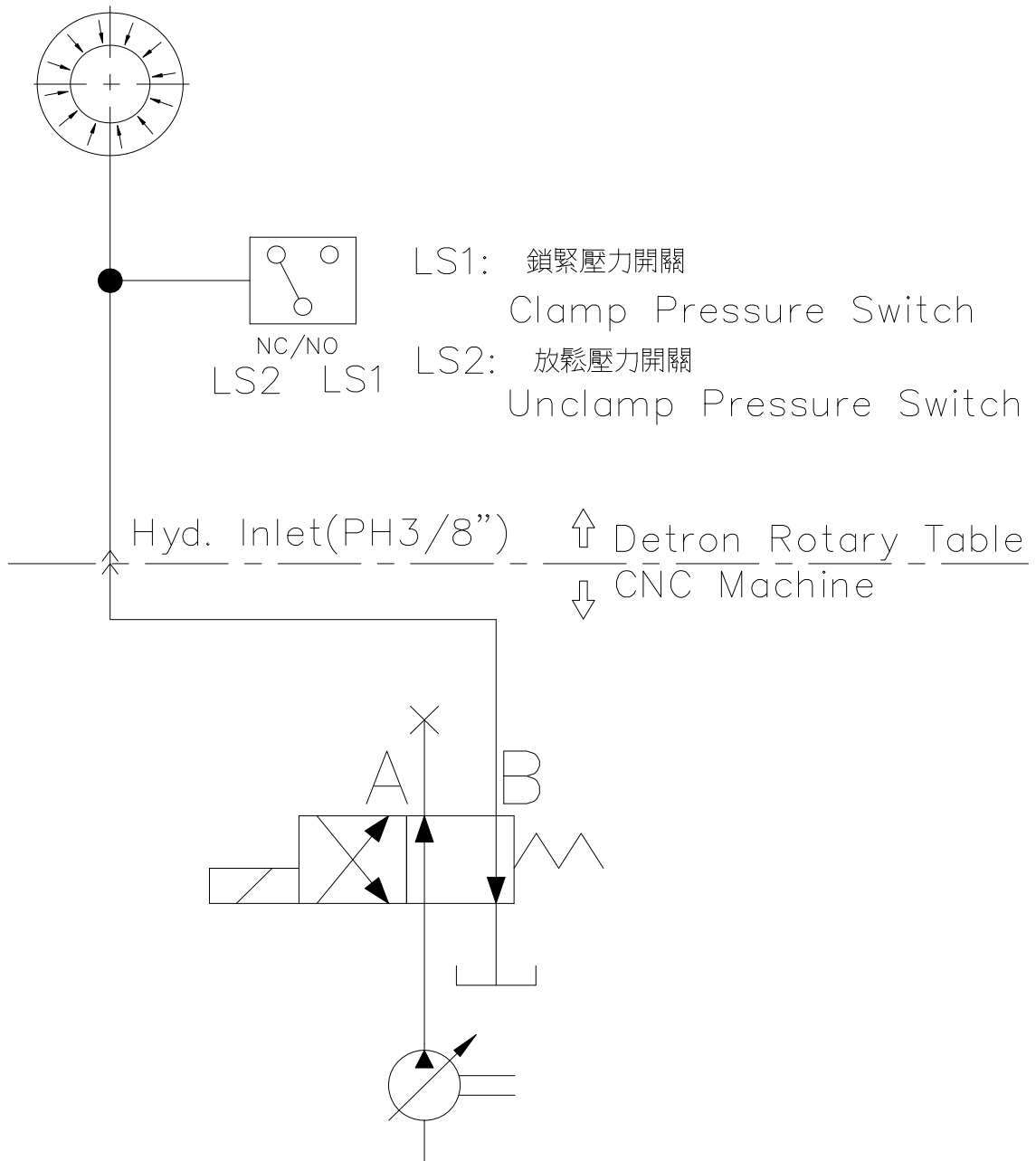
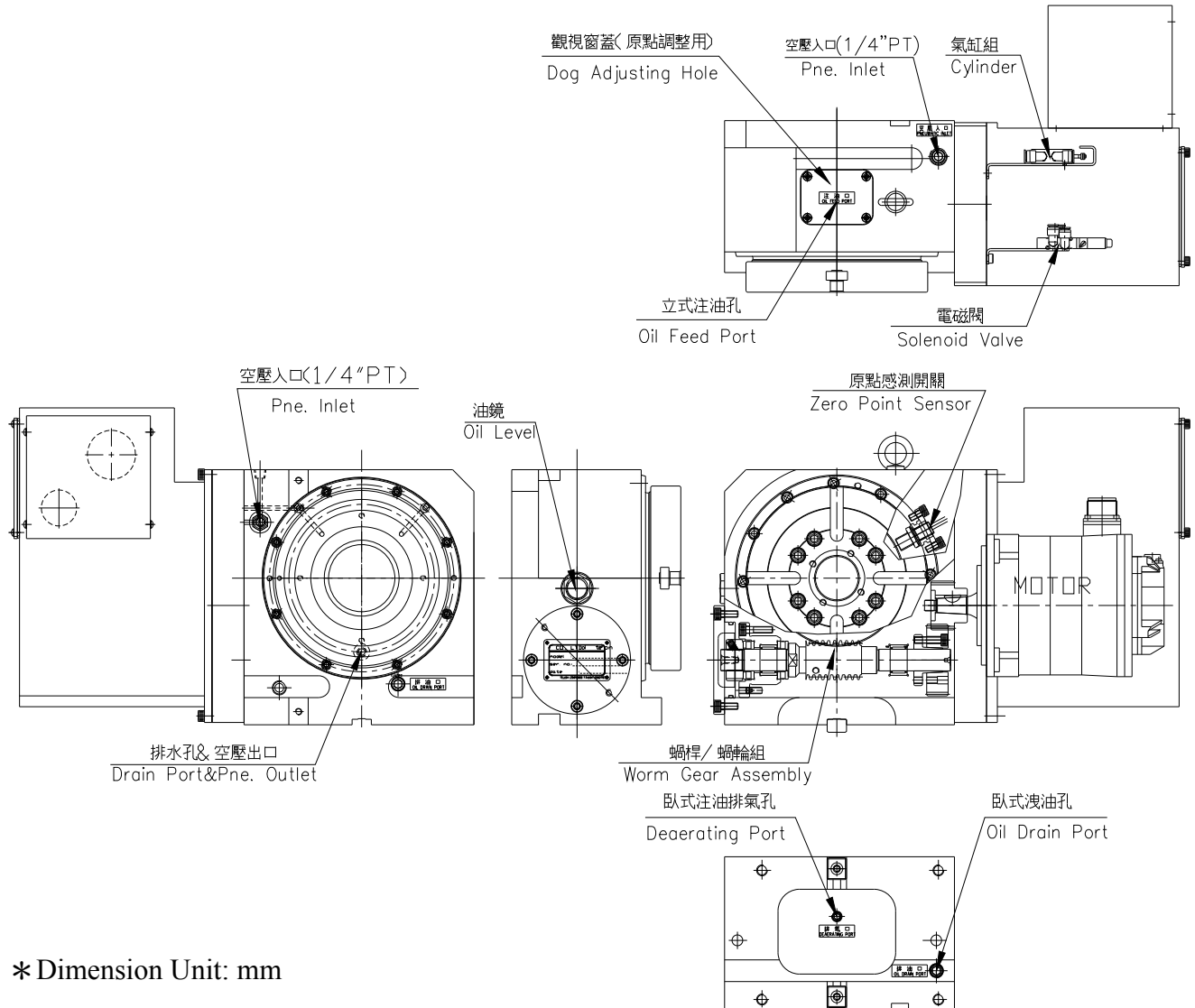

Fig 4-2

## Title

## 5.1 GX-P/PL/S Series Mechanism of Main Parts



\* Dimension Unit: mm

\* For GX-PL series, the motor cover is at the left of the worktable.

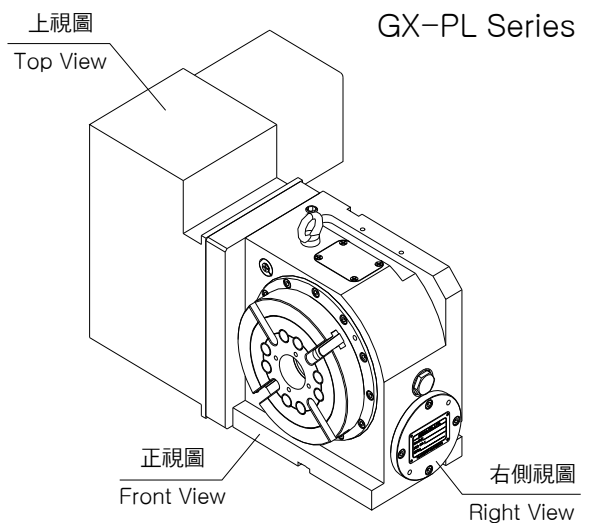
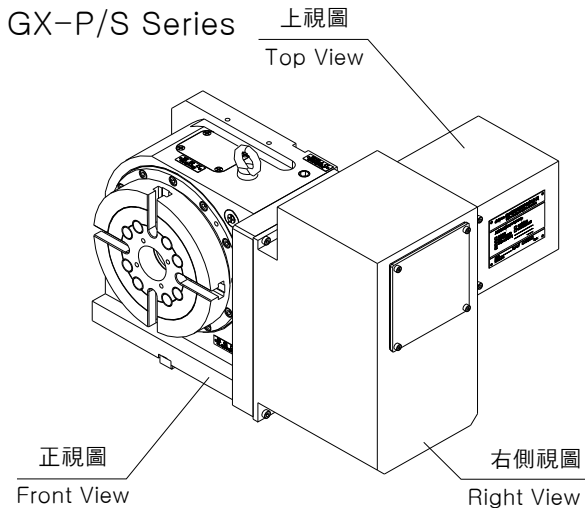
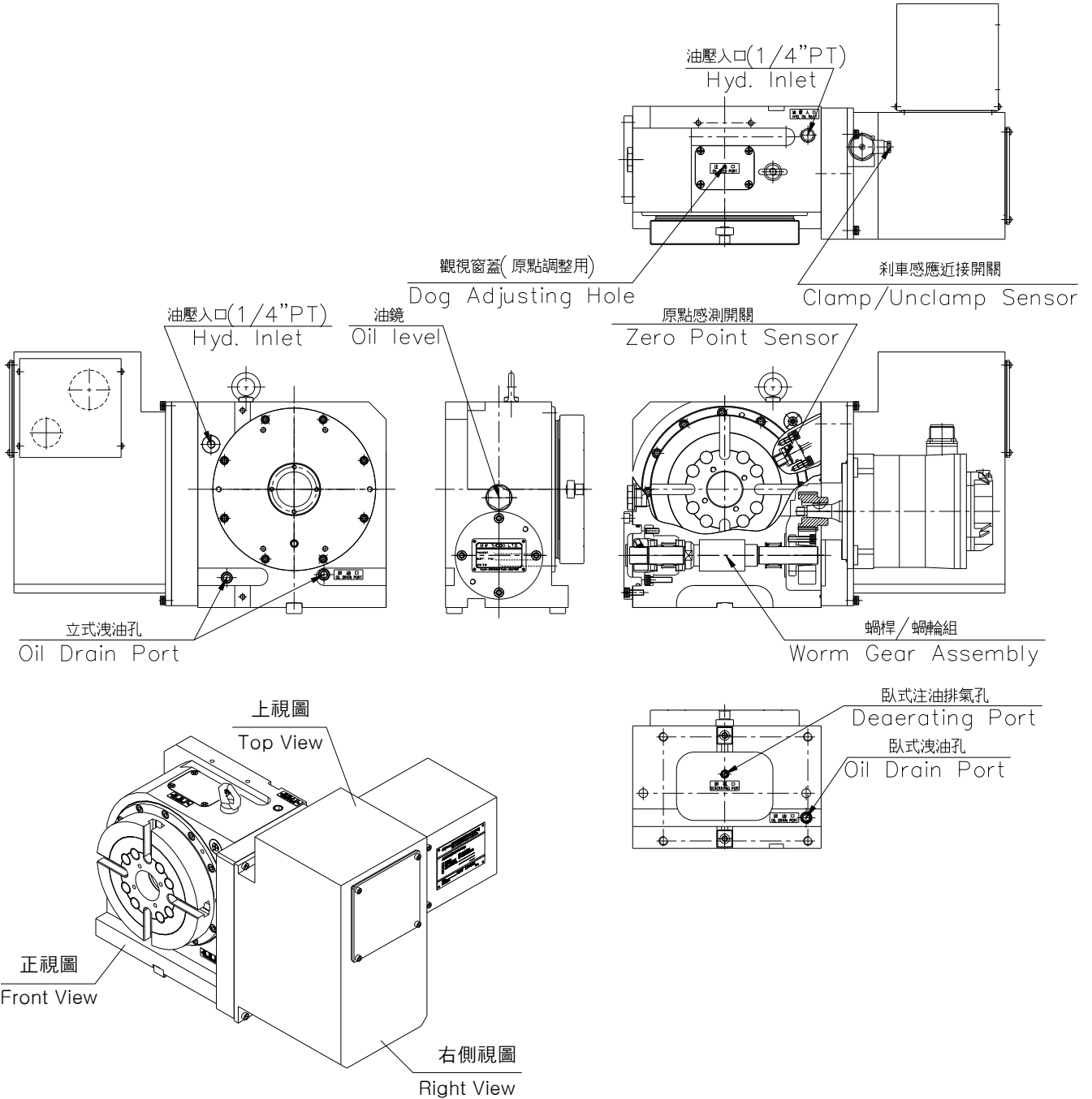

Fig 5-1



\* Dimensional Unit: mm

Fig 5-2

※ Prior to using the rotary table, prepare the machine in the following sequence:

#### A. Unpacking and preparation

Prior to using and commissioning the rotary table, prepare the follows:

(1).Unpack and remove the attaching parts from the rotary table.

(2).Wipe away the grease with a cleaning agent.

( Note : Do not use benzene, gasoline, or diesel which would produce rust. )

(3).Clean and de-burr the mounting surfaces and the rotary table.

(4).Mount the rotary table on the machine center. (see Fig 6-1) .

(5).Add Lubrication. (see Fig 5-1~5-2 · Page 11-1)

(6).Make sure that the electrical connection between the Rotary Table and the machine controller is well connected according to the attached electrical circuit diagram.(see *Electronic Circuit Diagram of packing*)

( Note : Switch off the main power of the machine center before connecting the electric cables. )

(7).GX-P/PL/S Series : Supply compressed air for clamping. (see Fig 5-1 · Page 10-1)

(Note: pneumatic source requires a F.R.L. Unit to ensure the suspending particulates are less than 5um for preventing solenoid valve and brake system from being clogged)

**GX-170/210H** : Supply hydraulic pressure for clamping and to eliminate the air in hydraulic oil. (see Fig 5-2 · Page 10-2)

(Note: Hydraulic oil needs filtration)

※Hydraulic circuit backpressure must be under 0.1MPa, to prevent the conditions of not unclamping completely or the extension of unclamping time of the brake mechanism when conducting unclamp command, because above conditions will cause mechanism damage or servo overload shut down.

(8).Set up rotary table parameters.

( see *Parameter Sheet of package* )

(9). Trial run.

(10).Set the grid shift amount for machine zero-return.

(see Page 8-2)

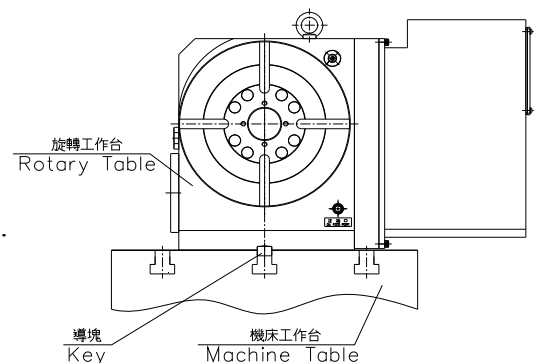

Fig 6-1

de tron	<b>6 Commissioning Procedure</b>
<b>Title</b>	6 Commissioning Procedure

**B. Trial run**

- (1). Make sure both the Rotary table mounting face and plate surface are clean.
- (2). Make sure the Rotary table is load-free.
- (3). Repeat clamp and unclamp functions; test for normal operation.
- (4). Check precision. (*see Inspection Certificate sheet of package*)
- (5). Rotate the CNC Rotary Table clockwise and counter-clockwise about twice at low speed (F300) for the first time, and make sure that the Rotary Table rotates smoothly, then gradually increase the speed up to the rapid speed.
- (6). Perform Zero reset, check for correct return to 0°.
- (7). Check different command operations by using NC operation commands.

- ※ **When an unclamp/clamp signal is detected, it is strongly suggested that a 0.5 sec. delay be applied before carrying out the subsequent command to ensure the table has completed the unclamping or clamping action. This is to prevent internal mechanism damage or overload of the servo motor.**
- ※ **Never start processing with the Rotary table before completing the above actions, otherwise mechanism damage may occur.**

de <b>tr</b> on	<b>7 PLC Flow Chart of Control System</b>
<b>Title</b>	7 PLC Flow Chart of Control System

To make sure detron Rotary tables are under good conditions when operating, please follow below PLC control circuit process for operation. (see Fig 7-1)

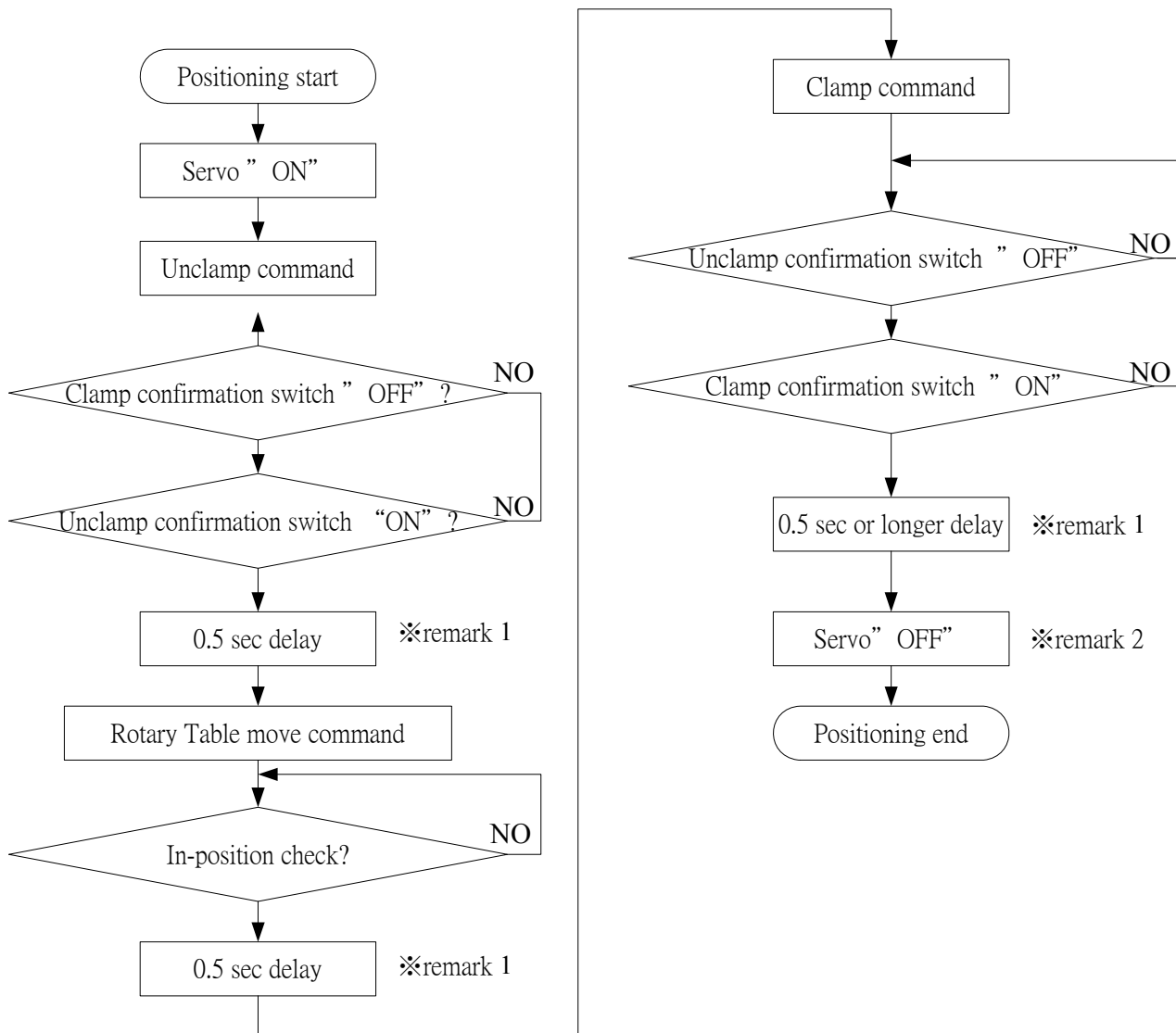

Fig 7-1

※ Remark 1 : Delay time is our recommended time, but actual delay time may differ depending on different rotary table operation conditions.

※ Remark 2 : When the unbalanced load makes a large current (70% or more of the rated current) occur in operation, turn the servo motor OFF. Turn the servo motor OFF as well when applying to full closed loop control.

de tron	<b>8 Zero Return Adjustment and Grid Shift Amount Setting</b>
<b>Title</b>	8.1 Zero Return Adjustment

Zero Reset of Rotary Table is achieved via detection of proximity switches.

Inactive or false action of proximity switch may be caused by the following conditions:

- Proximity Switch failure.
- Excessive distance between proximity switch and Zero Dog (remove proximity switch bracket, loosen nut and adjust the distance of proximity switch); the optimal distance shall be 1.0~2.0 mm. ( see Fig 8-1)
- Inaccurate relative position between proximity switch and Zero Dog. Open the cover of observation window, loosen screws on Zero Dog; move Zero Dog to a proper position and test for correct action. Replace the cover of observation window. (see Fig 5-1~5-2)

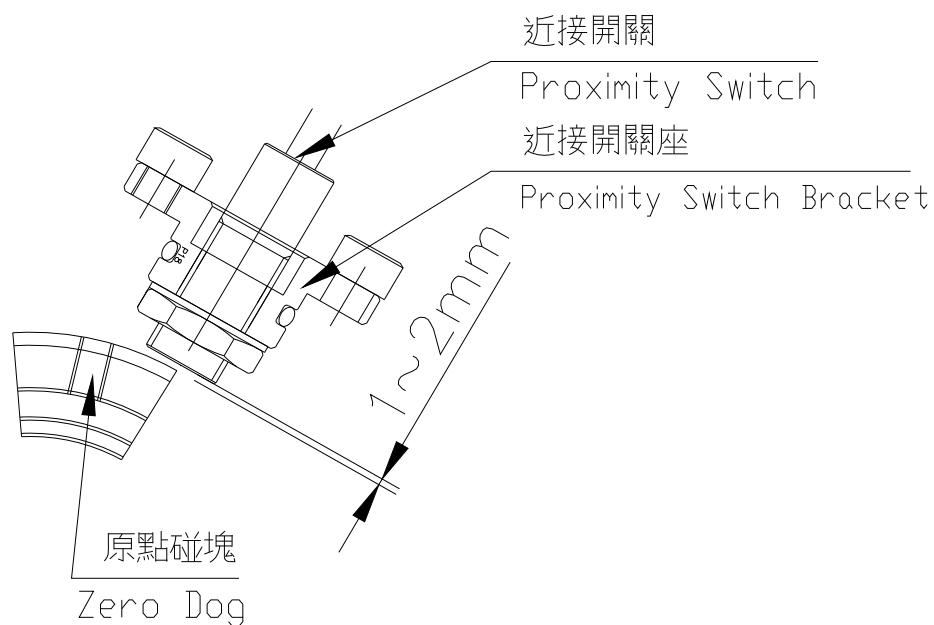

Fig 8-1

- (1).When the machine receives Zero Reset Command from NC controller, the Rotary Table will start to rotate in the specified forward direction to zero position.
- (2).When the Zero Dog touches the Proximity Switch, Rotary Table starts to decelerate for an accurate and prompt stop.( see Fig 8-3)
- (3).When the Rotary Table reduces its rotation speed, it will stop at Zero when a reference signal from the motor is received.
- (4).Perform turntable operation several times; measure errors between the actual stopping point and nominal stopping point of the Rotary Table. Enter the measurements into Zero Offset of the NC System for correction.

**NOTE :**

※In general, Zero Return is positioned when face plate T-slot is parallel to the bottom of the body, and the "0" position on the face plate indicates to the zero plate position.( see Fig 8-2)

※If the result is different, the computer parameter needs to be adjusted to achieve parallelism. The correction parameter shall not be of negative value. If a negative value occurs, it means the Zero Dog must be moved forward to a proper position for carrying out parameter adjustment.

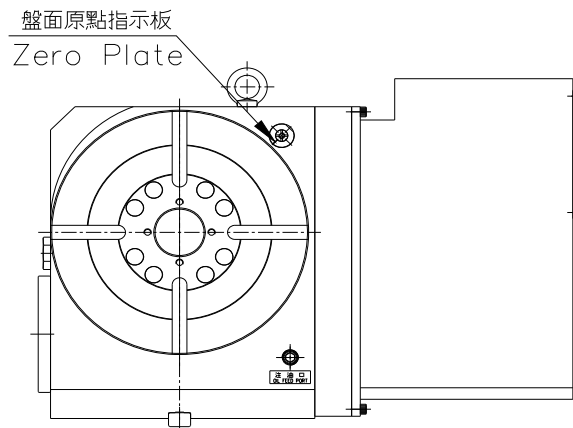

Fig 8-2

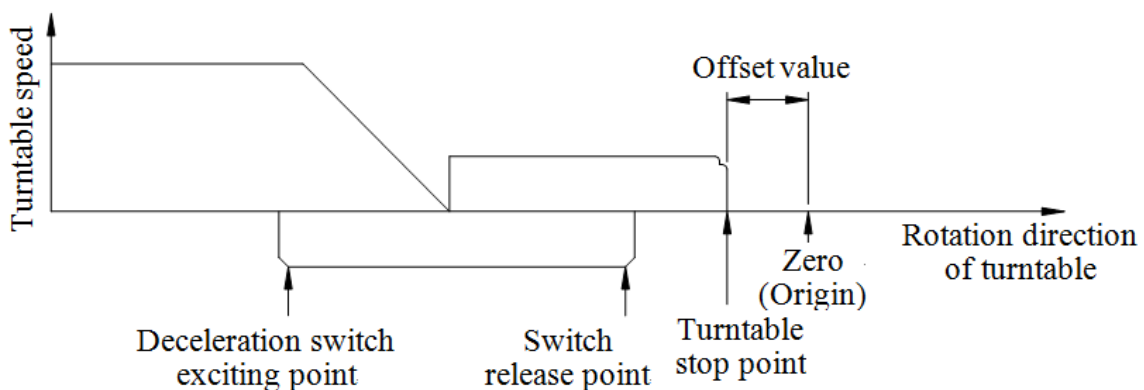

Fig 8-3

## Title

## 9.1 Worm Wheel and Worm Shaft Backlash Inspection

**Detron NC Rotary Table is highly reliable and meant for maintenance free. In order to maintain normal conditions for a prolonged period, some adjustments and maintenance are required.**

Excessive backlash between the Worm Wheel and the Worm Shaft will cause an undesirable effect between the Worm Wheel and the Worm Shaft when operating the Rotary Table. This not only affects processing accuracy of the work piece, but also directly reduces the service life of both the Worm Wheel and the Worm Shaft. When the backlash between the Worm Wheel and the Worm Shaft is too small, excessive heat may be generated by the Worm Wheel will cause the worm wheel seized. In order to maintain long-term operation of the machine, the proper gap between the Worm Wheel and the Worm Shaft must be checked periodically. (see Page 9-1)

《Inspection Procedure》 (see Fig 9-1)

- (1). Make sure that braking mechanism of the measuring axis is in released state, and the servomotor is in the OFF state.
- (2). Place dial gauge pin on the inner side of the T-slot.
- (3). Place a steel plate into the T-slot of face plate.
- (4). Slowly turn the face plate manually by using the steel plate, exert a 15 to 20 kg force clockwise or counter clockwise; release the force immediately after exerting it, allow the gauge to resume a steady reading. Followed by doing the same in the reverse direction and read the reading. The difference between two readings of the dial gauge is the value of the gap between gears.
- (5). Method for measuring the backlash: Take 4 points on the Worm Wheel in  $90^\circ$  intervals (Rotary Table rotation angle). Make one measurement every  $90^\circ$  and take the average.
- (6). At  $20^\circ\text{C}$  environmental temperature, the proper backlash between the Worm Wheel and the Worm Shaft should be 10 to 15 seconds. Adjustment is required if otherwise.

**※Based on thermal expansion principle, this backlash value should be properly adjusted in accordance with surrounding temperatures.**

**※Room temperature for using the rotary table :  $5^\circ\text{C} \sim 40^\circ\text{C}$ .**

The turntable is still operable even when the backlash exceeds the upper limit listed above. When a backlash adjustment is required, and the backlash correction value is entered into the NC Unit by using parameter methods, then the backlash value becomes 0.

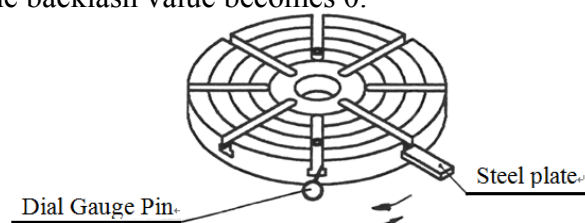

Fig 9-1

※ Adjusting an excessive backlash(see Fig 9-2)

- (1).Evenly loosen the Adjusting Screw 1/2 turns counterclockwise.
- (2).Evenly tighten the Locking Screw clockwise. This makes the worm shaft axis move forward to reduce the backlash.  
(The order to tighten the Locking Screw : L1->L2->L3->L4->L5->L6)
- (3).Measure the backlash as described on the previous page.(see Page 9-1)
- (4). Based on the measurement, adjust the Adjusting Screw repetitively until the standard backlash value is reached. (see Page 9-1)

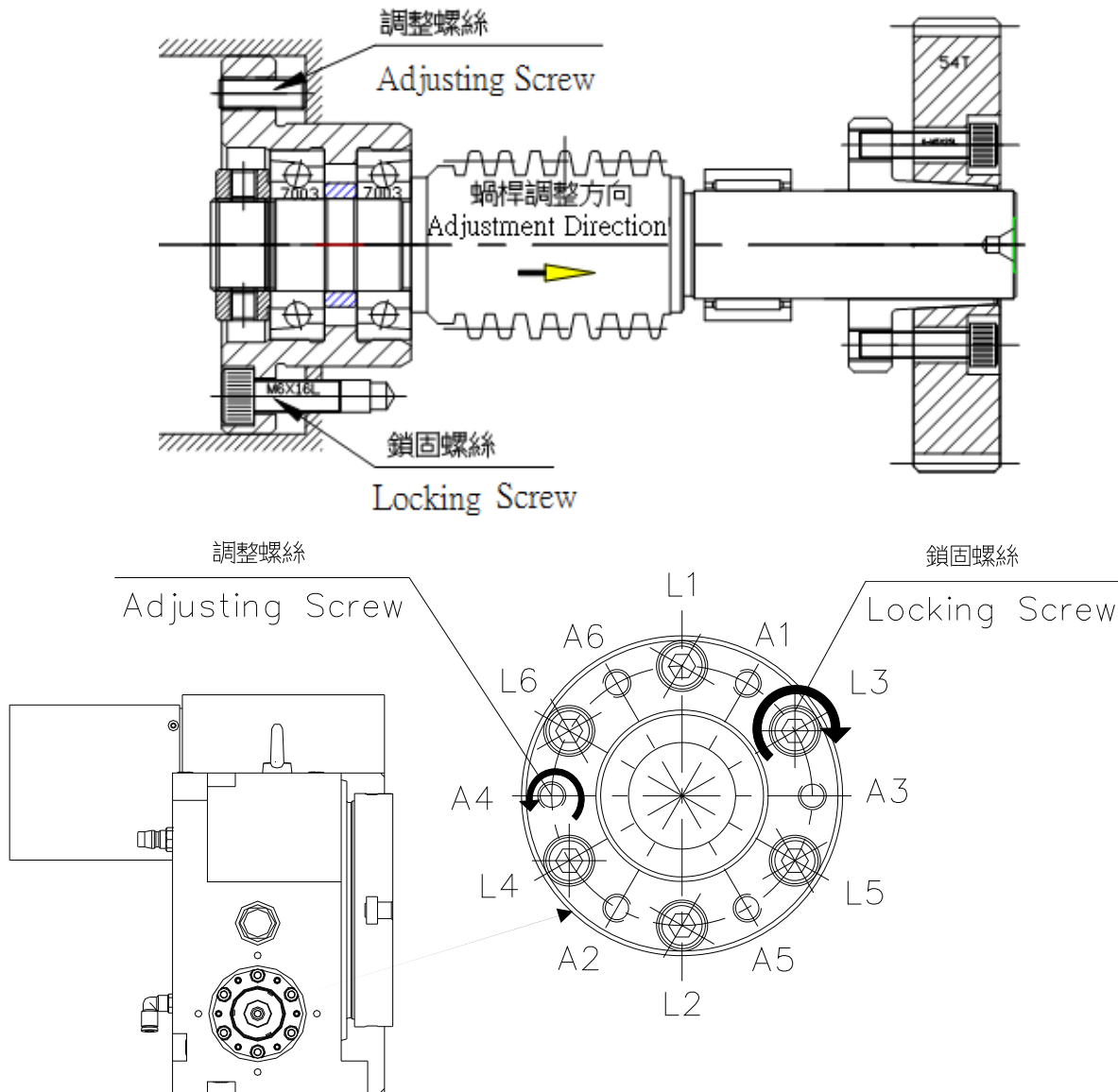

Fig 9-2

## Title 9.2 Worm Wheel and Worm Shaft Backlash Adjustment

### ※ Adjusting an insufficient backlash(see Fig 9-3)

- (1).Evenly loosen the Locking Screw 1/2 turns counterclockwise.
- (2). Evenly tighten the Adjusting Screw. This makes the worm shaft axis move backward to reduce the backlash.  
( The order to tighten the Adjusting Screw : A1->A2->A3->A4->A5->A6 )
- (3).Evenly tighten the Locking Screw clockwise.  
( The order to tighten the Locking Screw : L1->L2->L3->L4->L5->L6 )
- (4).Measure backlash as described on the previous page. (see Page 9-1)
- (5).Based on measurement, adjust the Adjusting Screw repetitively until the standard backlash value is reached. (see Page 9-1)

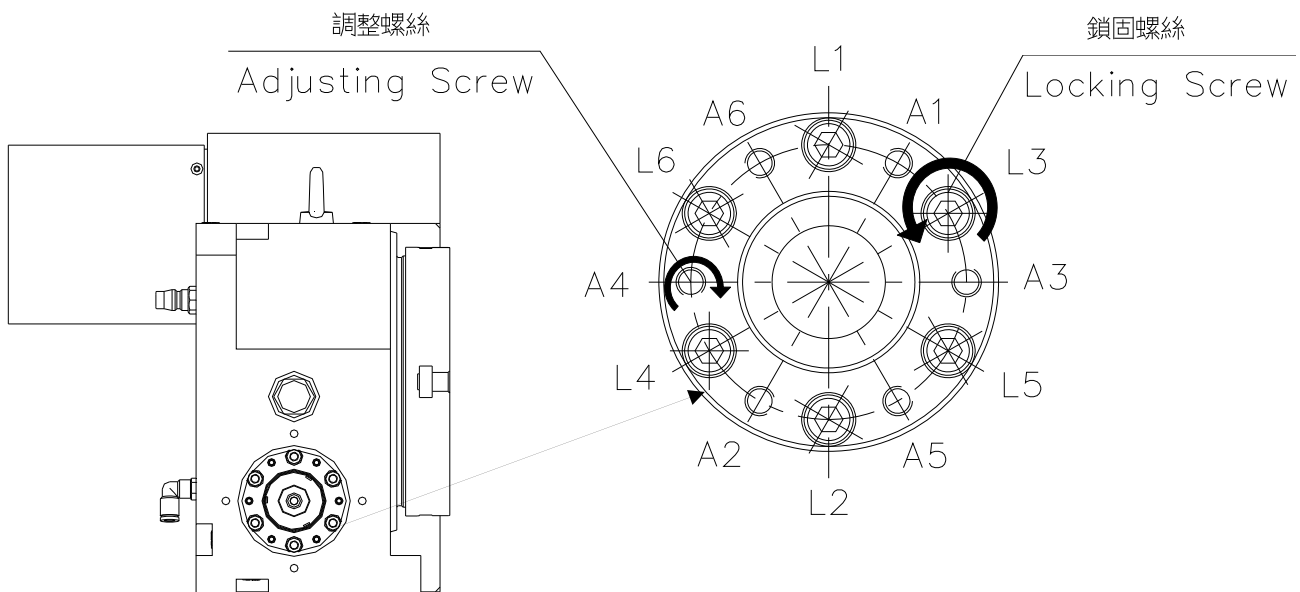
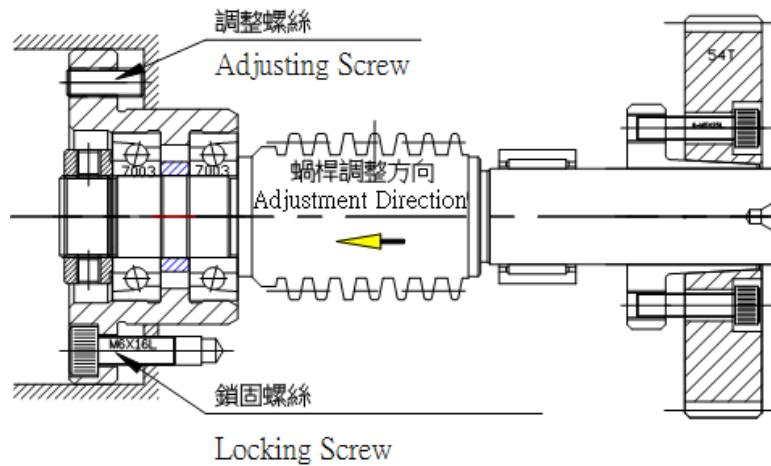

Fig 9-3

## Title 9.3 Transmission Gear Backlash Adjustment

※ Adjusting Backlash of the Gear(see Fig 9-4)

- (1).Remove the Motor Cover.
- (2).Loosen the Motor Adapter Locking Screw.
- (3).Push Motor Adapter downward, so that there is no backlash between motor gear teeth and the Worm Shaft.
- (4).Place dial gauge on the body.
- (5).Adjust gear center distance in the arrow direction (backlash increases when Motor Adapter moves up, decreases when Motor Adapter moves down).
- (6).Standard backlash.

Model	GX125	GX170/210
Backlash(Dimensional unit : mm)	0.044 ~ 0.058	0.042 ~ 0.055

- (7).Tighten Motor Adapter Locking Screws.
- (8).Replace the Motor Cover.

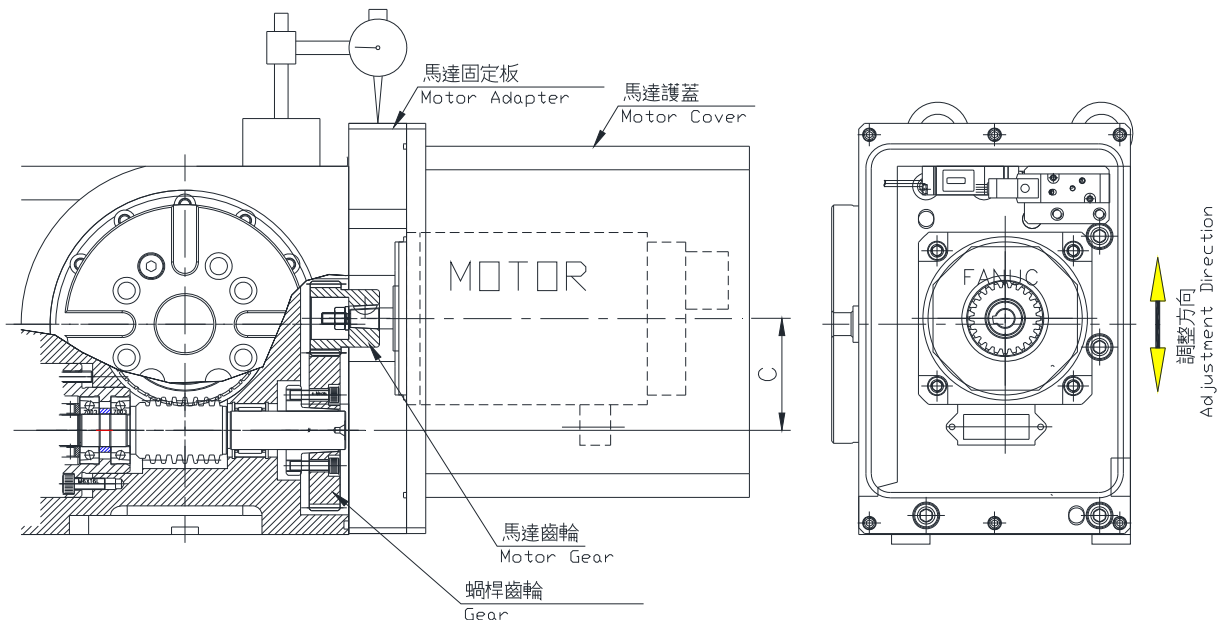

Fig 9-4

de <b>tr</b> on	<b>10 Clamp/Unclamp Device</b>
<b>Title</b>	<b>10.1 Pneumatic Clamp/Unclamping Device</b>

After placing a work piece, make sure to tighten the rotary table. Processing without tightening the rotary table will cause quick wear or damage of the worm wheel as well as tool and work piece damage. When adjusting the angle of the rotary table or performing continuous cutting, always confirm that the rotary table is in the released state. To ensure the correct state, always check the Clamp/Unclamp signal for correct indication.

In order to achieve proper clamp torque, the rotary table requires a pneumatic pressure of 0.5~0.7 MPa and the compressed air must flow through an air filter, pressure regulator and lubricant filter. Two connection terminals (1/4"PT) are provided with the product, at the top and the rear; select one for use.

**※ On monthly basis, open the drain hole cover at the back of rotary table and check for any moisture ingress from the pipeline. If water ingress exists, improve the F.R.L. Unit on the machine.**

**※ Solenoid valve set and pneumatic brake mechanism are high precision designs. To maintain proper functionality, the F.R.L. Unit accuracy requirement is under 5um, so as to prevent solenoid valves or the brake mechanism from being clogged by suspending particles and causing a machine stop.**

The solenoid valve on the machine controls the Clamp/Unclamp action. When power is switched on and the Clamp is selected, the piston in the solenoid valve is pushed forward by compressed air when the valve receives the Clamp command, causing the brake disk clamping on the Rotary Table. Friction at this time is the clamping torque.

A reed switch on the single movement pneumatic cylinder is provided to detect the Clamp/Unclamp state of the Rotary Table. Pressure setting of the switch is 0.2~0.3 MPa.

**※ When an unclamp/clamp signal is detected, it is strongly suggested that a 0.5sec. delay be applied before carrying out the subsequent command, to ensure the table has completed the unclamping or clamping condition. This is for preventing internal mechanism damage or overload of the servo motor.**

de <b>tr</b> on	<b>10 Clamp/Unclamp Device</b>
<b>Title</b>	<b>10.2 Hydraulic Clamp/Unclamping Device</b>
<p>After placing a work piece, make sure to tighten the rotary table. Processing without tightening the rotary table will cause quick wear or damage of the worm wheel as well as tool and work piece damage. When adjusting the angle of the rotary table or performing continuous cutting, always confirm that the rotary table is in the released state. To ensure the correct state, always check the Clamp/Unclamp signal for correct indication.</p> <p>In order to achieve proper clamp torque, the rotary table requires 2.5MPa hydraulic pressure; when applying a lower pressure, clamping torque will be lower accordingly, two connection terminals (1/4"PT) are provided with the product, at the top and the rear, select one for use.</p> <p>After receiving clamping command, hydraulic oil flows to the drum brake, drum brake will clamp the rotary table evenly, so that the rotary table can reach the best and accurate clamping torque. When receiving unclamping command, hydraulic oil will be released, the brake pressure disappears and the drum brake returns it's original form, so that the rotary table will be under unclamping condition.</p> <ul style="list-style-type: none"> <li>※ <b>While the hydraulic oil flows to the drum brake, it also flows to related mechanism for showing unclamp/clamp of the rotary table. At the time in clamp, the dog activating piston (when hydro-oil acting the piston) shift upwards, the proximity switch (LS51) shows the rotary table is clamped. At the time in unclamp, the dog activating piston shift downwards, the proximity switch (LS52) shows the rotary table is unclamped.</b></li> <li>※ <b>When mechanism switch clamping, the actuating pressure is more than 1~1.2MPa.</b></li> <li>※ <b>When mechanism switch unclamping. the actuating pressure is less than 0.8MPa.</b></li> <li>※ <b>When using pressure switch for unclamping/clamping, the actuating pressure range is 1.8~2.2MPa.</b></li> <li>※ <b>When hydraulic oil is mixed with air, the clamping torque can't reach the expected performance; then we need to exhaust the air. Please follow the instruction below:</b> <ol style="list-style-type: none"> <li>(1). <b>Adjust the oil pressure to 2MPa (to prevent the mass oil spilling over the hole).</b></li> <li>(2). <b>Loosen the bolts on the top of the body for 1/4~1/2 loop.</b></li> <li>(3). <b>Repeat unclamp and clamp commands, then the hydraulic oil mixed with air will drain out. Till the oil draining out is no longer with air, tighten the bolts, the air exhausting process is completed.</b></li> </ol> </li> <li>※ <b>Hydraulic circuit backpressure must be under 0.1MPa, to prevent the conditions of not unclamping completely or the extension of unclamping time of the brake mechanism when conducting unclamp command, because above conditions will cause mechanism damage or servo overload shut down.</b></li> <li>※ <b>When an unclamp/clamp signal is detected, it is strongly suggested that a 0.5sec. delay be applied before carrying out the subsequent command, to ensure the table has completed the unclamping or clamping condition. This is for preventing internal mechanism damage or overload of the servo motor.</b></li> </ul>	

**Title****11 Lubrication Replacement**

Lubricant is a key factor to performance and service life of your machine. Always use lubricants recommended in the manual.

Model	GX125	GX170	GX210
Oil quantity required in machine body Unit: Liter	0.5	0.8	1

※ Precautions for replenishing and replacing lubricant.

(1) Selection of lubricant is based on several features :

- a. The Oil film strength, rust resistance and oxidation resistance.
- b. The viscosity class shall be within ISO-VG100~150.

※ Since lubricants engulf the Worm Wheel, Worm Shaft and other respective parts, quality products must be used to ensure satisfactory operation.

※ Recommended Ambient Temp. range is 18°C~40°C under normal usage, Contact Lubricant mfg for suggested lubricant product if the temp. is higher or lower than the recommended range.

mfg	Product
Shell	Omala 150
Esso	Spartanep 150
Mobile	Mobile Gear 629
JoMo	Reductus 100

(2) Pay attention to keep the lubricant clean; always clean up auxiliary tools for replenishing oils. Never allow external dust and debris entering the oil tank.

(3) DO NOT mix lubricants of different brands since their ingredients are different; mixed use may impair lubrication properties.

(4) Replenish the oil to the centerline of the oil level window (*see Fig 5-1~5-2 for oil level position*).

(5) Replace the lubricant every 6 months or after 1200hr operation; check oil amount from time to time and replenish as necessary.

No.	Symptom	Cause	Check	Solution
1	Turntable not turning (1) Motor not running	* Cable damage	*Check cable and end connections	* Refer to electric circuit diagram
	(2) Motor idle running	*Tapered sleeve slackened	*Check all gears	* Fix again
2	Turntable runs not smoothly	* Overload	* Check load and gyration inertia * Check motor operation at that time * Check operation condition at low-speed.	* Reduce the load or stop processing this workpiece
3	Noise when rotating	*Faulty fixation of gears in gear box * Incorrect lubrication * Slackened operation (Residual hydraulic pressure) * Damaged worm wheel, worm shaft or gear in gear box	*Check equipment condition *Check lubricant type and quantity * Check clamp part and turntable clamps (Slackened) pressure switch control	*Re-calibrate *Replenish or replace lubricant * Calibrate tooth face or replace gear
4	Motor over-current	* Faulty zero offset	* Over current only when tightened	* Re-do zero offset
		* Overload operation * Backlash of worm wheel and worm shaft too small or uneven * Insufficient warm-up time or incorrect parameter setting	* Check load * Check backlash *Check program	* Alter load or loading method *Adjust backlash * Revise program
5	Inaccuracy (1) Poor division precision	*Insufficient Hyd. pressure *Incorrect solenoid valve spec. * Pipeline clogged * Worm Wheel face worn out	*Check pressure *Check solenoid valve spec. *Check solenoid valve condition *Check pipeline * Measure backlash	*Adjust pressure * Replace with correct solenoid valve spec. * Replace solenoid valve * Replace pipeline *Adjust backlash
	(2) face plate face undulation or center sway	*Slackened nut of shaft bearing	*Compare with precision tolerance	*Contact detron or dealer
6	Clamp/Unclamp operation (1)No Clamp/Unclamp signal	*Signal line connection defect * Improper adjustment of switch equipment *Pressure switch damaged	*Check signal cable	*Re-adjust *Replace pressure switch
	(2) Delayed signal output	* Hydraulic filter screen clogged * Insufficient hydraulic pressure	*Check filter screen *Check pipeline for clog or fracture *Check hydraulic pressure supply system for normal operation	*Replace pipeline
7	Clicking sound in cutting operation. (1)When starting to cut after emplacing workpiece	* External force * Clamping action	*Check cutting condition *Check tightening tool and turntable clamp (or unclamp) pressure switch	*Correct cutting condition *Adjust backlash
	(2) In continuous cutting	* Excessive worm wheel backlash * Poor teeth engagement	* Measure gear backlash	*Adjust backlash